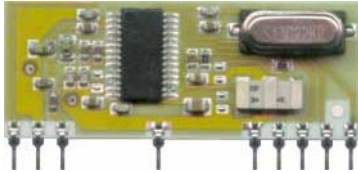

RRQ3-XXX**AM Superhet Receiver with Crystal Oscillator and Squelch Circuit****General description**

The RRQ3-XXX is an AM superhet data receiver with PLL synthesizer and crystal oscillator.

A squelch function is implemented to reduce output

"noise" when no transmitter is active.

Receiver Frequency: 315 / 433.92 / 868.35 MHz

IF Frequency: 10.7MHz

Typical sensitivity: -106 dBm

Supply current: 5 mA (typ)

XXX: custom-specified working frequency
(315, 433.92, 868.35 MHz)

Applications

- Wireless security systems
- Car Alarm systems
- Remote gate controls
- Sensor reporting

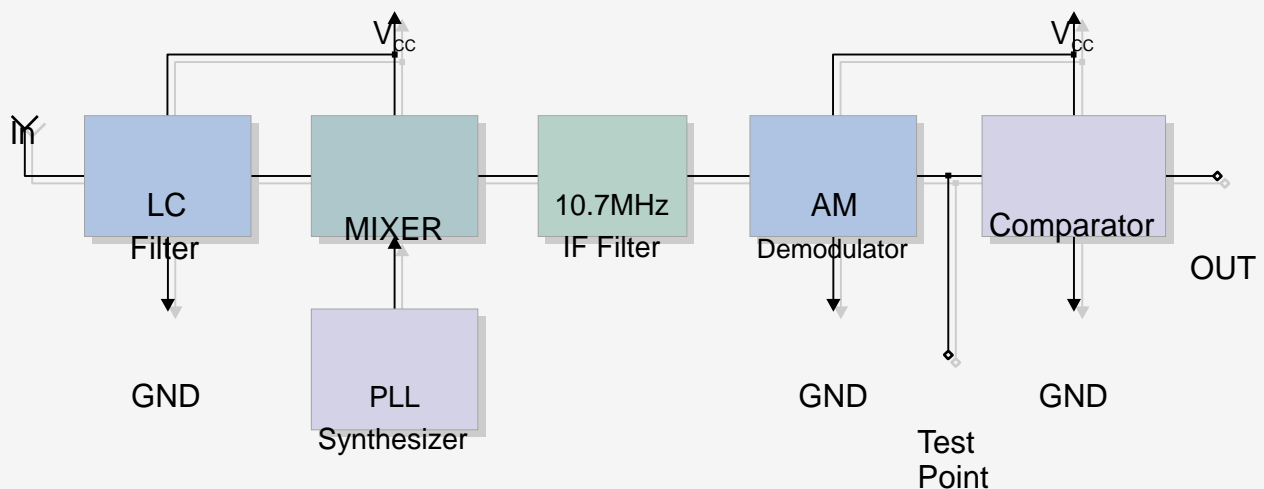
BLOCK DIAGRAM

Electrical Characteristics

Ta = 25°C unless otherwise specified

CHARACTERISTICS		MIN	TYP	MAX	UNIT
V _{CC}	Supply Voltage	4.5	5	5.5	VDC
I _S	Supply Current		5	6	mA
F _R	Receiver Frequency		315/433.9/868.35		MHz
	RF Sensitivity (100% AM)		-106 / -106 / -101		dBm
B _w	-3dB Bandwidth		±150		KHz
	Max Data Rate			4.8	Kbit/s
	Level of Emitted Spectrum			-70	dBm
V _{ol}	Low-Level Output Voltage (I=10uA)			0.8	V
V _{oh}	High-Level Output Voltage (I=-200uA)	V _{CC} - 1			V
T _{OP}	Operating Temperature Range	-25		+80	°C

Pin Description

1	V _{CC}	12	V _{CC}
2	GND	13	Test Point
3	IN	14	OUT
7	GND	15	PD (Power Down)
11	GND		

PD = 0V ---> RX OFF (I_{Standby} = 100nA)
 max) PD = 5V ---> RX ON

Mechanical Dimensions

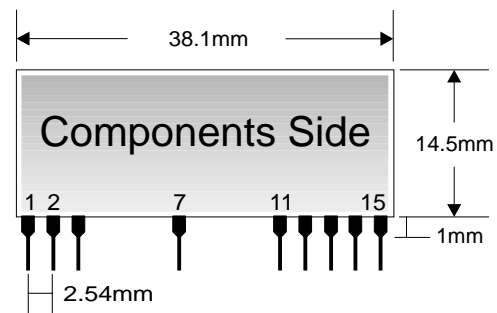

TYPICAL APPLICATION

