

Application Note

SH50050 Series Ceramic Tilt Sensor ñ

Mounting, Electrical/Signal Conditioning, and Thermal Considerations

MOUNTING CONSIDERATIONS

Sensors should be mounted using #2/56 screws and washers. Using a torque wrench, tighten screws to 60 inch ounces (1.5 meter-grams). (DO NOT USE an adhesive between the sensor and the mounting surface.)

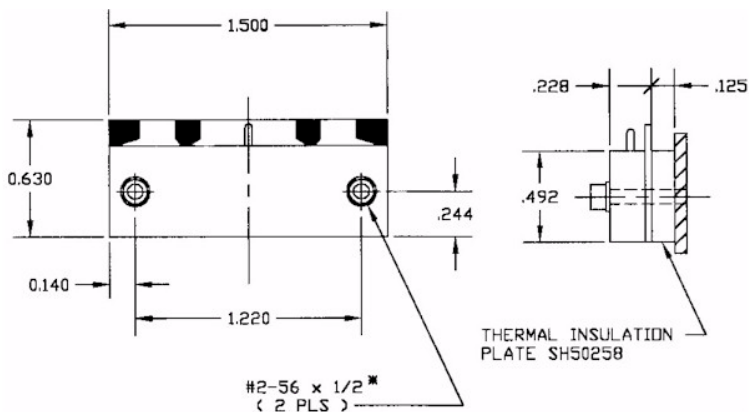

**Note: Model SH50054/SH50055 shown above.
Dimensions will vary for other models!**

ELECTRICAL AND SIGNAL CONDITIONING

The sensor is partially filled with a conductive fluid that will be degraded if any DC current is applied. Therefore, only AC excitation voltages may be used. Spectron offers the SA40012 signal conditioner which not only drives the sensor with a symmetrical AC wave form, but is also insensitive to the sensor's large impedance changes between the operating temperature extremes. The SA40012 provides the user with a DC voltage output that can be interfaced to a display or an analog to digital converter. The SA40012 has the capability to compensate for the scale factor variation caused by the expansion and contraction of the electrolyte with

temperature. The SA40012 utilizes CMOS based ICs to drive the sensor with a minimal current which reduces self heating, noise level, and maximizes null stability.

THERMAL CONSIDERATIONS

The SH50050 series of ceramic sensors utilize a 96% Alumina Oxide material for the body and contact plate. This material has a thermal conductivity of $66 \times 10^{-7} / \text{degree C}$, which dramatically reduces the thermal settling time needed to stabilize its quiescent temperature. However, this characteristic makes the sensor very susceptible to thermal gradients. Depending on the application, internal heat generation and external thermal operating conditions, the sensor can either be hard mounted to a thermally conductive heat sink (aluminum, copper), or insulated using a material such as p/n SH50258, as shown.

The sensors are constructed with flat outside surfaces used for proper orientation to mount the sensor flat against a vertical surface, as well as providing an excellent path for temperature flow. The symmetrical geometry of the sensor creates a uniform distribution of the ambient temperature, resulting in an even change in fluid volume. When using the sensor close to a high heat source (such as a HeNe laser tube), every effort should be made to symmetrically distribute the heat and reduce end to end thermal gradients.

駿融企業有限公司 JIN ZON ENTERPRISE CO., LTD.

104 台北市長安東路二段 171 號 4 樓之 3

4F-3, No. 171, Sec. 2, Chang An E. Rd., Taipei, Taiwan, R. O. C.

TEL: 886-2-27111093~5

FAX: 886-2-27310902

E-mail: jinzon@ms2.hinet.net

Http:// www.jinzon.com.tw/