

- **Stainless steel**
- **Internal mounting**
- **Temperature range to 120°C**
- **Pressure up to 40 bar**
- **User configurable N/O or N/C action**



## Model SSF29

The SSF29 series is a horizontally mounted device designed to achieve reliable switching at higher pressures. Mounting is in the side of the tank from the inside, so requires access to the inside of the tank.

This type is capable of working at pressures of up to 40 bar.

They are manufactured in 316 grade Stainless Steel, for those liquids and environments that require the use of Stainless Steel and will work in liquids of SG 0.7 minimum.

The switch action may be reversed by removing the float, inverting it and then refitting it to the stem.

Crydom Part No : SSF29X035

### TECHNICAL SPECIFICATIONS

Mounting style	Internal	Cable length - standard	350
Mounting thread	1/8" BSP	Cable size	17/0.10 - AWG22
Float & Stem material	316 grade	Cable conductor material	Tinned copper
Maximum Temperature	120°C	Cable sheath material	XLPE
Maximum Pressure	40 bar	Cable temperature rating	125°C
Float SG	0.6	Sealing gasket	Not supplied
Minimum fluid SG	0.7	Tightening torque for fixing nut	2.0kg/cm

### ELECTRICAL SPECIFICATIONS

Contact type	N/O or N/C
Switching Power VA	50
Switching current max A	0.5
Switching voltage AC	300
Switching voltage DC	300
Breakdown voltage min DC	600

All ratings are for resistive load only

### OUTLINE DIMENSIONS

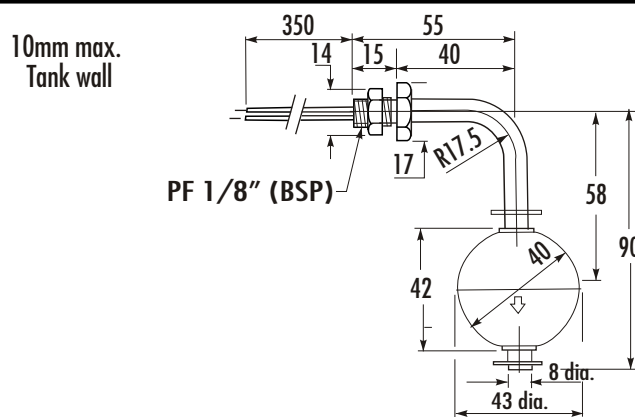

#### CONTACT US NOW

**UNITED KINGDOM**  
**CRYDOM**

**T** +44 (0) 1202 897969

**F** +44 (0) 1202 891918

**E** [magnetics@crydom.com](mailto:magnetics@crydom.com)

**W** [www.crydom.co.uk](http://www.crydom.co.uk)

#### USA

**CRYDOM**

**T** +1 619 2101600

**F** +1 619 710 8540

**E** [sales@crydom.com](mailto:sales@crydom.com)

**W** [www.crydom.com](http://www.crydom.com)

**Model SSF29**  
**liquid level sensors**

