

**SPECIFICATION
of
THERMOPILE
INFRARED SENSOR
UNIT**

TSE 01/08 L

PART NO. :				Rev. 1.0
------------	--	--	--	----------

1. SCOPE

This specification describes a Thermopile Infrared Sensor Unit for non-contact temperature measurement

2. TYPE of UNIT

2.1. TYPE NAME

Thermopile Infrared Sensor Unit

2.2. MODEL NO.

TSE 01/08 L

3. DIMENSIONS

See Fig. 1.

Production Lot No. is put on a Unit.

4. GENERAL CHARACTERISTICS

Table 1

PARAMETER	STANDARD
4.1. Thermopile Sensor	8 Element Linear Array Unit Thermopile (3 Digital Address Signal Inputs, Built-in 8ch Analog Multiplexer)
4.2. Optics	Silicon Lens
4.3. Outputs	Thermopile Signal Output (for Incident Infrared Energy Detection) Thermistor Signal Output (for Ambient Temp. Detection) (* Both analog outputs are supplied individually.
4.4. Time Constant	Max.30msec.
4.5. Circuit Configuration	See Fig. 2
4.6. Detection Area	See Fig. 3
4.7. Crosstalk	See Fig. 4
4.8. Detecting Temperature Range	-20 ~ 100 deg Celsius
4.9. Accuracy 1 Accuracy 2	Within (+/-) 2 deg Celsius (Open) Within (+/-) 1 deg Celsius (Heat Source 60 ~ 80 deg Celsius)
4.10. Operating Temperature	0 ~ 70 deg Celsius
4.11. Storage Temperature	-20 ~ 90 deg Celsius
4.12. EEPROM	128w*8bit,1kb Serial Interface 2-Wire (* For Calibration Data Input

5. ELECTRICAL CHARACTERISTICS

Table 2

PARAMETER	CONDITION	STANDARD
5.1 Thermopile Signal Output	Object Temp. : 72 deg Celsius Ambient Temp. : 20 deg Celsius Distance : 250 mm	2.40 V (+/-) 1.2 % (After each element correcte)
5.2 Temperature Characteristics of Thermopile Signal Output	Object Temp. : -20 ~ 100 deg Celsius (Ambient Temp. : 10 ~ 50 deg Celsius) When Ambient Temp. 70 deg Celsius, Object Temp. : 20 ~ 100 deg Celsius	See Data 1
5.3 Thermistor Signal Output	Ambient Temp. : 20 degrees Celsius	0.484 V (+/-) 3 %
5.4 Temperature Characteristics of Thermistor Signal Output	Ambient Temp. : 10 ~ 50 deg Celsius	See Data 2
5.5 Reference Voltage	25 deg Celsius	1.225 V (+/-) 25%
5.6 Supply Voltage	Single Power Supply	5 V DC (Maximum Rating : 5.25 V DC)
5.7 Current Consumption	+Vs = 5 V Supply	Max. 5 mA
5.8 Output Current	Short Circuit to Ground	Max. 60 mA

6. MEASUREMENT METHOD

6.1. Thermopile Signal Output

See Fig. 5.

7. NOTES

7.1. Design restrictions/precautions

For outdoor applications, be sure to apply suitable supplementary optical filter, drip-proof and anti-dew construction. This Unit is designed for indoor use.

In cases where secondary accidents due to operation failure or malfunctions can be anticipated, add a fail safe function to the design.

7.2. Usage restrictions/precautions

To prevent Unit malfunctions, operational failure or any deterioration of its characteristics, do not use this Unit in the following, or similar, conditions.

7.2.1 Use in rapid environmental temperature changes.

7.2.2 Use in strong shock or vibration.

7.2.3 Use under the condition where there are obstructing materials (Glass, Fog, etc.) through which infrared rays cannot pass within detection area.

7.2.4 Use in fluid, corrosive gases and sea breeze.

7.2.5 Continual use in high humidity atmosphere.

7.2.6 Use in field of static electricity or strong electromagnetic waves.

7.2.7 Use under the condition exposed to direct wind from a heater or air conditioner.

7.3. Handling and storage restrictions/precautions

To prevent Unit malfunctions, operational failure, appearance damage or any deterioration of its characteristics, do not expose this Unit to the following or similar, handling and storage conditions.

7.3.1. Vibration for a long time.

7.3.2. Strong shock.

7.3.3. Static electricity or strong electromagnetic waves.

7.3.4. High or Low temperature and humidity for a long time.

7.3.5. Corrosive gases or sea breeze.

7.3.6. Dirty and dusty environments that may contaminate the optical window.

PART NO. :				Rev. 1.0
------------	--	--	--	----------

Unit troubles resulting from misuse, inappropriate handling or storage are not the manufacturer's responsibility.

TOP VIEW

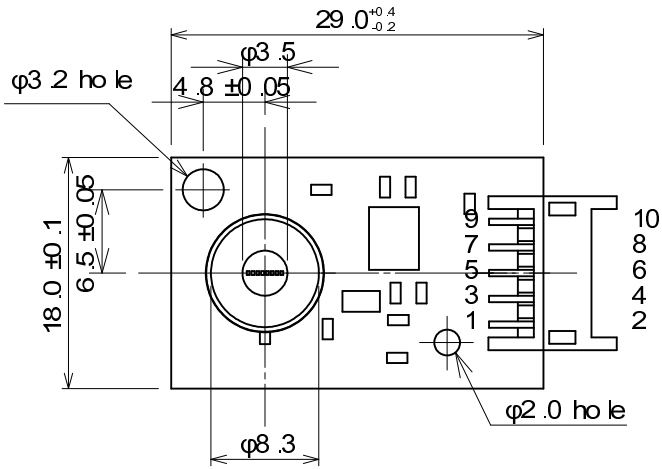

Pin Arrangement

- 10 : SELECT NUT A
- 9 : SELECT NUT B
- 8 : +Vs
- 7 : SELECT NUT C
- 6 : No Contact
- 5 : Vtp (Thermopile Signal Output)
- 4 : Vntc (Thermistor Signal Output)
- 3 : SDA
- 2 : Ground
- 1 : SCL

SIDE VIEW

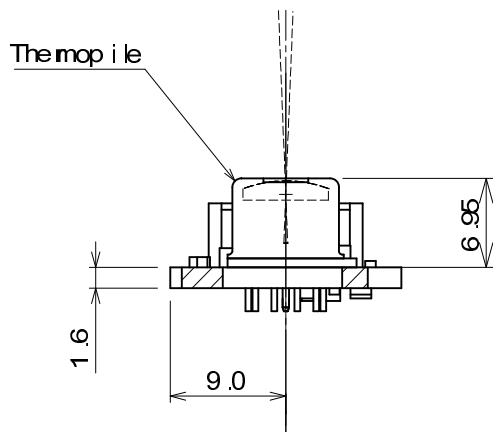
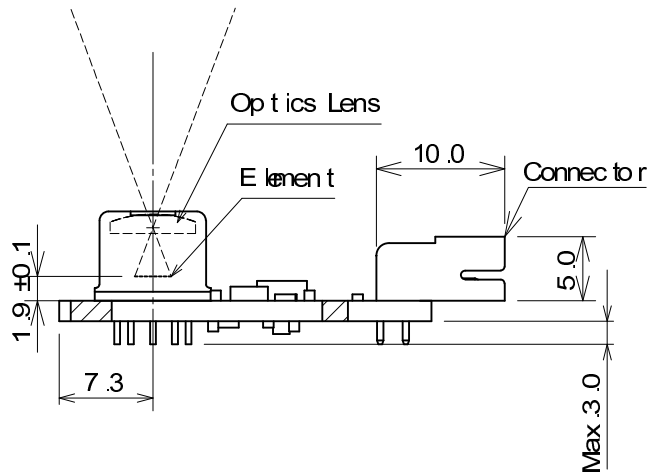

Tolerance : ± 0.2

Fig. 1 : Dimensions, units in mm

PART NO. :				Rev. 1.0
------------	--	--	--	----------

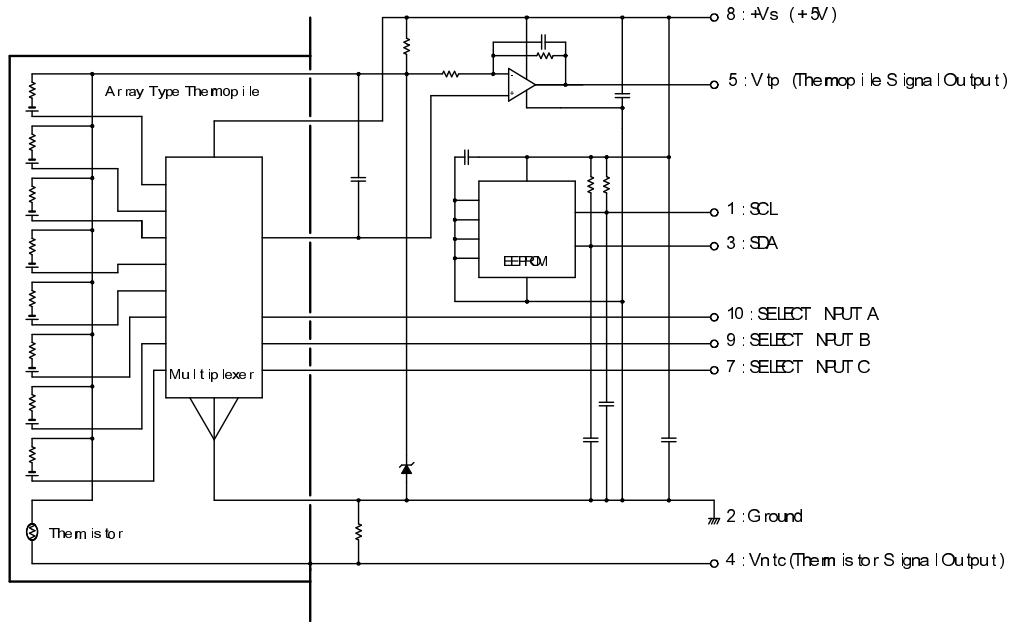

Fig. 2 : Circuit Configuration

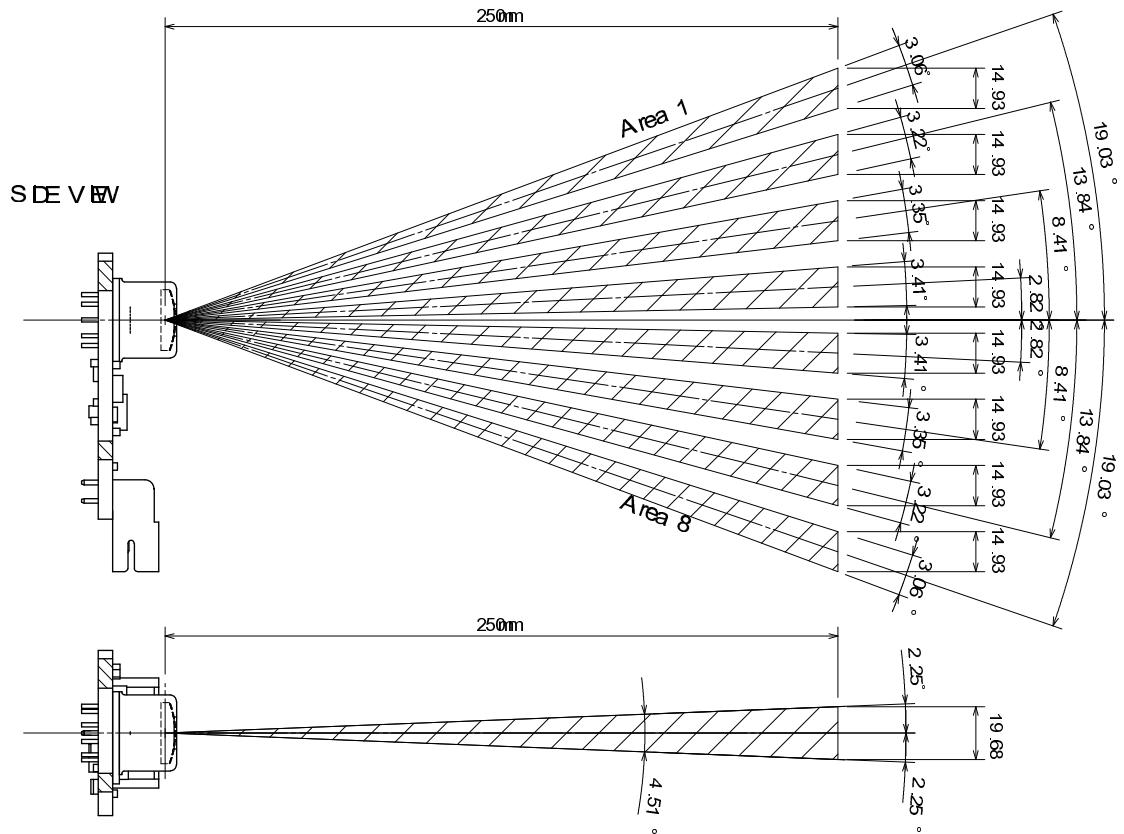

Fig. 3 : Detection Area

PART NO. :				Rev. 1.0
------------	--	--	--	----------

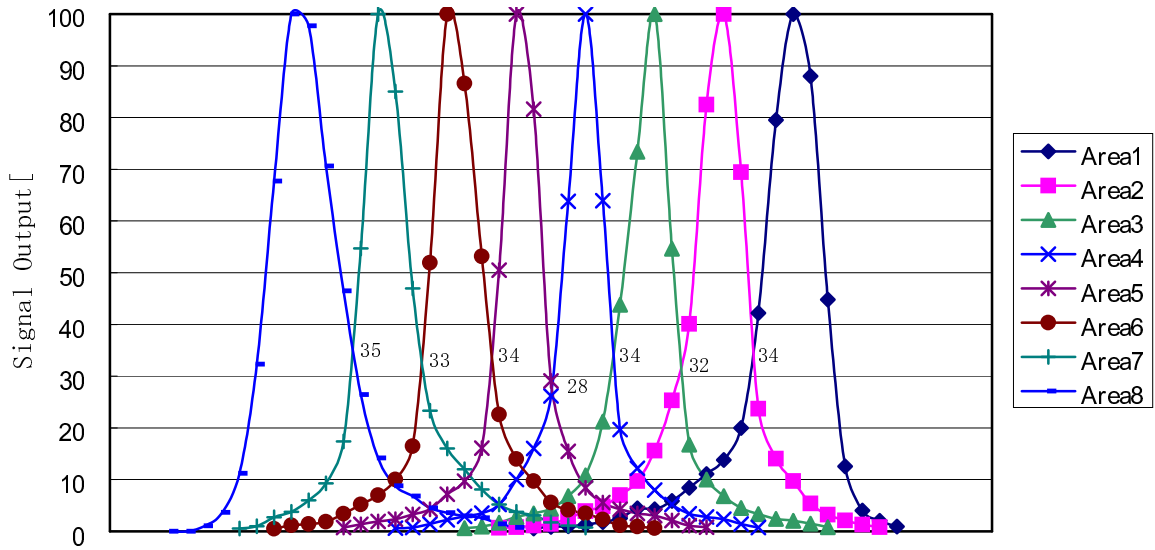
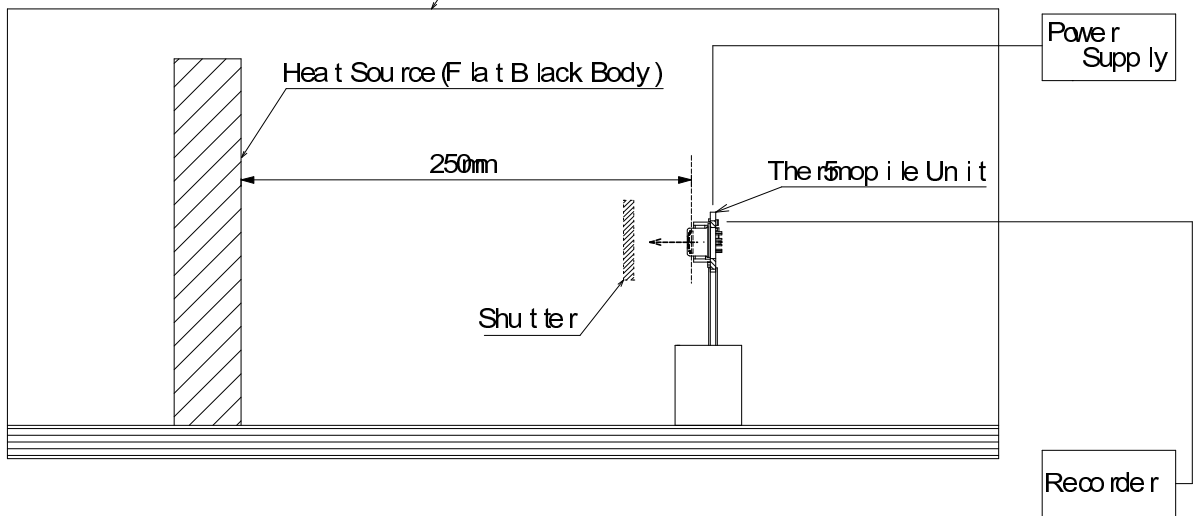

Fig. 4 : Crosstalk (Typ. Value)

Cover Box (Temp. Controlled inside Box)



Object temp. : 72 degrees Celsius
 Ambient Temp. : 20 degrees Celsius
 Distance : 250 mm
 Supply Voltage : 5 V
 Reference Voltage : Typ. 1.225 V

** Thermopile Signal Output Shutter On/Off
 Shutter On(Open) : Infrared Incidence
 Shutter Off(Close) : Infrared Cut-off

Fig. 5 : Test Set-up Block Diagram

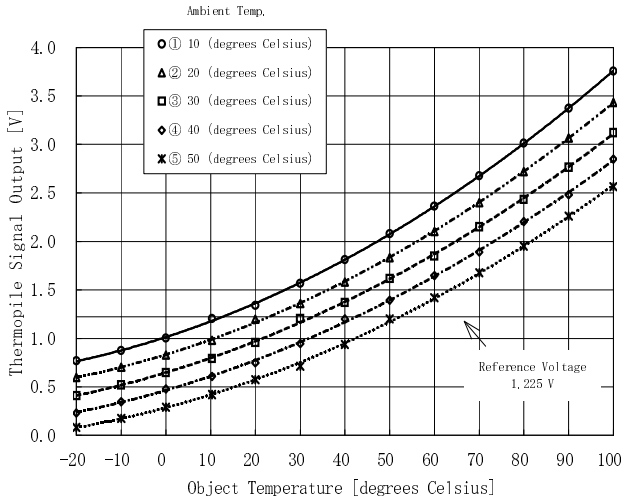

Ambient Temp. (degrees Celsius)	Typical Thermopile Signal Output for Object Temp. (degrees Celsius) [V]											Data		
	-20	-10	0	10	20	30	40	50	60	70	80		90	100
10	0.769	0.874	1.003	1.201	1.341	1.570	1.812	2.090	2.365	2.675	3.011	3.372	3.758	①
20	0.595	0.700	0.828	0.981	1.199	1.358	1.582	1.831	2.100	2.400	2.721	3.065	3.434	②
30	0.409	0.519	0.647	0.790	0.969	1.203	1.370	1.618	1.849	2.150	2.435	2.765	3.120	③
40	0.232	0.346	0.479	0.609	0.718	0.946	1.201	1.396	1.649	1.891	2.200	2.481	2.830	④
50	0.083	0.176	0.288	0.421	0.575	0.714	0.937	1.202	1.421	1.676	1.963	2.282	2.565	⑤

* Distance : 250 mm

Data 1 : Temperature Characteristics of Thermopile Signal Output

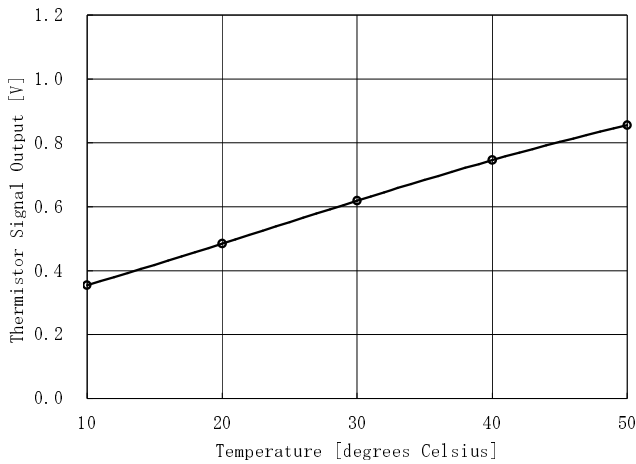

Temp. [degrees Celsius]	10	20	30	40	50	Data
Typical Thermistor Signal Output [V]	0.355	0.484	0.619	0.746	0.856	①

* Reference Voltage : Typ. 1.225 V

Thermistor

Resistance : Typ. R = 100 kohm (at 25 [degrees Celsius])
Beta Value : 3955K (+/-) 0.5 % (T1/T2 : 0/50 [deg Celsius])

Data 2 : Temperature Characteristics of Thermistor Signal Output

Select Inputs			Selected Pixel
A	B	C	
H	L	H	1
H	H	H	2
L	H	H	3
L	L	H	4
L	H	L	5
H	L	L	6
L	L	L	7
H	H	L	8

Multiplexer Truth Table