

Comus Group of Companies

PRODUCT DATA SHEET

Manufactured in UK

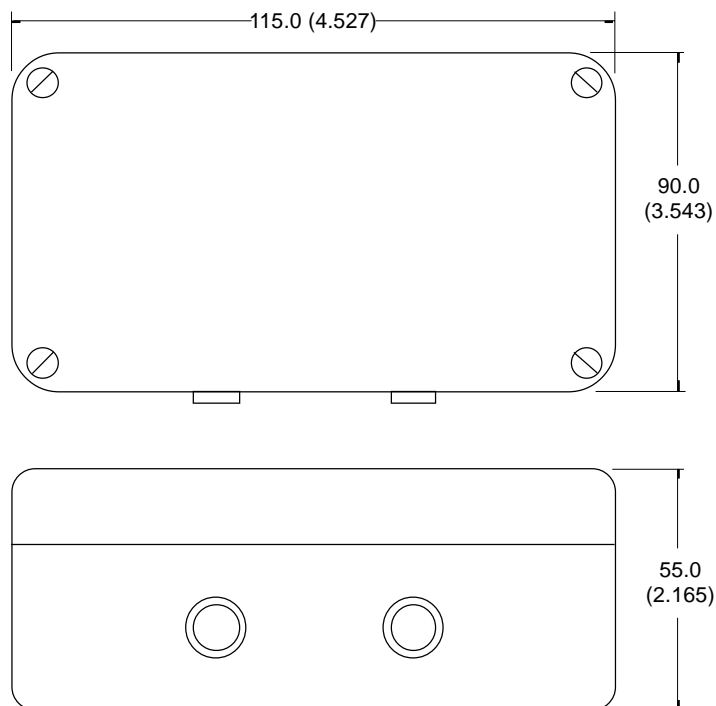

Drawings not to scale
All dimensions in mm (inches) nominal

SPECIFICATION

SUPPLY VOLTAGE	Max. Vac	240
SWITCHING CURRENT	Max. A	10
SWITCHING CAPACITY	Max. VA	240
OPERATING TEMPERATURE	Deg. °C	-10° +50°
STORAGE TEMPERATURE	Deg. °C	-25° +70°
CASE MATERIAL		ABS
Relay Coil Diode Protected		
Output Contacts Varistor Protected		
IP65 sealed case subject to cable exit		

FS Relay Unit is designed to be used in conjunction with standard liquid sensors in order to enhance and increase their switching capabilities. It can also be used with most of our proximity and tilt switches.

FS RELAY UNIT

PART NUMBER
S1386

Rev. No.	Revision Note	Date	Signature
B	Web site 2001	1-4-01	RG

The Comus Group of Companies consist of:
Assemtech Europe Limited
E. Bachem GmbH
Comus International
W. Gunther GmbH
Gunther Belgium
Gunther France
S.T.G.

As part of the company policy of continued product improvement, specifications may change without notice. Our sales office will be pleased to help you with the latest information on this product range and details of our full design and manufacturing service. All products are supplied to our standard conditions of sale otherwise agreed in writing.