

RXQ2 - XXX GFSK MULTICHANNEL RADIO TRANSCEIVER

- Intelligent modem RF Transceiver
- RF Data Rates to 100 kbps
- Selectable 'Narrowband' RF Channels
- Crystal controlled RF design
- Supply Voltage 3.3V
- Serial Data Interface with Handshake
- Host Data Rates up to 38,400 Baud
- Very Stable Operating Frequency
- Operates from -20 to +70 °C
- Low profile ceramic DIL package

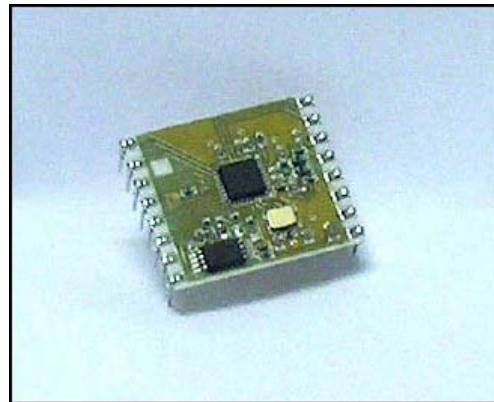

RXQ2 radio transceiver

Operating Modes

- One to one
- Broadcast
- One to many
- Many to one

Applications

- Wireless Security System
- EPOS Terminals
- Sensor Data Logging
- Remote Control
- Remote Meter Reading

Description

The RXQ2 radio transceiver module provides a reliable wireless communications for the transfer of data at Gaussian Frequency Shift Keying (GFSK), Manchester encoded, RF data rates of up to 100 kbps. Their unique features of narrow band operation and user channel selection combined with excellent interference rejection make them an ideal choice for next generation applications. The transceivers have the functions of a complete radio modem and simply require CMOS/TTL data at the transmit input and the corresponding transceiver(s) output the same data. Preamble and CRC are automatically generated and added to the RF transmission.

Operating within the 433 (868) MHz band the module operates in user selectable channels. The RXQ2 can use any channel in 100 (200) kHz steps. The modules both use a crystal controlled design which provides narrow band performance which is far superior to other wideband 'SAW' based designs.

Possible applications include one-to-one and multi-node wireless links in applications including car and building security, EPOS, inventory tracking, remote industrial process monitoring and computer networking. Because of their small size and low power requirements, both modules are ideal for use in portable, battery powered applications such as hand-held terminals.

Part Number Description Package

Part Number	Description	Package
RXQ2-433	Hybrid Multichannel Radio Transceiver	16 pin DIL
RXQ2-868		

Pinout & Mechanical Details

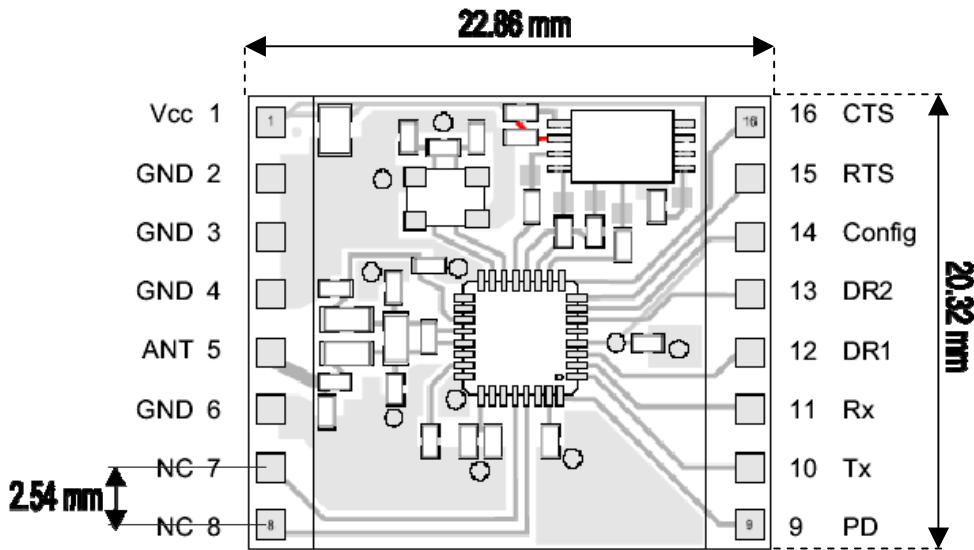

Pin Descriptions

Pin Number	Name	Type	Description
1	Vcc	Power	Positive supply voltage connection. Decouple with 100nF ceramic capacitor to ground
2,3,4,6	GND	Power	Connect to 0 volts
5	Antenna	In / Out	Nominal 50 Ohm input/output impedance capacitively isolated from the internal circuit
7,8	n.c.	---	No connection
9	PD	In	Power Down pin. Ground : Power Down Mode; +Vcc : Operating Mode
10	TX (UART)	In	Transmit data input from host controller. Data input to the transmitter can be directly interfaced to CMOS logic drive operating on the same supply voltage as the transceiver. Serial port setup : 1 start, 8 bit, 1 stop, no parity
11	RX (UART)	Out	Received data output to host controller (CMOS logic out) representing true data as supplied to the transmitter. Serial port setup : 1 start, 8 bit, 1 stop, no parity
12,13	Data Rate	In	Host Data Rate selection (see next table)
14	Configuration	In	Ground : Configuration mode; +Vcc : Operating mode.
15	RTS	In	Logic '0' is Request To Send. Take low when the host is ready to send data to the module or is ready to receive data from the module.
16	CTS	Out	Logic '0' is Clear To Send. Taken high when the module is busy.

Host Data Rate Selection

DR1 (pin 12)	DR2 (pin 13)	Baud Rate
Gnd	Gnd	4,800
Vcc	Gnd	9,600
Gnd	Vcc	19,200
Vcc	Vcc	38,400

Technical Specifications

- Absolute Maximum Rating**

Operating temperature:	-20 °C to +80 °C
Storage temperature:	-40 °C to +100 °C
Supply Voltage:	1.9V to 3.6V
Data input/output:	-0.3V to Vcc+0.3V

- Electrical Characteristics**

	Min.	Typ.	Max.	Units	Notes
DC Levels					
Supply voltage	1.9	3.3	3.6	V	1
Supply current (Transmit mode)	11		30	mA	
Supply current (Receive mode)		12.5		mA	
Supply current (power down mode)		125		uA	
Data input/output high	Vcc-0.3		Vcc	V	
Data input/output low	0		0.3	V	
RF					
Working frequency : RXQ2-433 RXQ2-868	430.0 860.0		440.0 880.0	MHz	2
Receiver sensitivity		-100		dBm	
Transmitter RF power out		+10		dBm	
Frequency deviation		+/-50		kHz	
GFSK Manchester encoded data rate		100		kbps	
Operating temperature	-20		+70	°C	
Dynamic Timing					
Power up to stable receiver data out		30		msec	
Power up to full RF out		30		msec	
Standby to Receive mode		1		msec	
Standby to Transmit mode		1		msec	

Notes

- Supply voltage should have <10mV ripple
- The application operating frequency must be chosen to comply with the Short Range device regulation in the area of operation

Applications

The RXQ2 wireless module has applications in many areas where reliable half duplex communications are required over ranges up to 200 meters. The crystal controlled narrow band design, in the embedded RXQ2 transceiver, gives reliable performance within the 433 (868) MHz band.

The addressing protocol employed enables many different configurations such including:

one-to-one operation: for point to point data communication;

broadcast operation: where a single master address many RXQ2 modules concurrently (using many RXQ2

modules set to the same address);

one-to-many: a network consisting a master and many slaves (the receivers all have the same address)

many-to-one: where the transmitters all send to a single receiver address

Because each RXQ2 can contain a unique address, multiple RXQ2 network can co-exist in the same area.

Operation

The Host Data Rate pins (12,13) are read when the PD switch goes high (pin 14 = Vcc). The RXQ2 must be put into standby mode by taking the PD pin low (pin 14 = GND) in order to change the selection.

The size of RF data packets are set during configuration. If fewer bytes are received by the RXQ2 transceiver than the preset size, then after 10ms from the last byte received from the host, the RF packet will be processed (expanded to meet the preset packet size) and transmitted. The RF data packet size must be set the same for transmitter and receiver, otherwise the received packets will be discarded.

In order to optimize data rate, in a point-to-point configuration where data is mostly being sent in one direction, the packet size for one data direction can be set to the maximum size, however the reverse direction may be set to a smaller packet size, to implement an acknowledge reply for example.

The RTS pin overrides the timeout value. If a short data packet is sent, RF transmission will start as soon as the RTS pin is taken 'high' after the last byte is sent to the module.

The RXQ2 contains an on-board data buffer equal to two data packets. Therefore if RTS is asserted (then the host is unable to receive data) the RXQ2 will store a max of two data bytes, all further data packets received will be discarded.

No RF packets will be received by the module when it is in power down mode.

Each RXQ2 has its own preset address. This is set during configuration. Any data received is examined and the address header, embedded within the data packet, is compared with the RXQ2 address. Only data received with matching address will be processed and output to the host, all other data will be discarded.

All RXQ2 modules are shipped with a default address of 7E7E7E7E.

RXQ2 configuration

The configuration of the RXQ2 module may be changed by setting the Configuration switch low (Pin 14 = GND) and sending a set of configuration data bytes to the module on TX pin.

Byte	Name	Description	Default Value (hex)
0	Destination Address	MSB	7E
1			7E
2			7E
3		LSB	7E
4	RXQ2 Address	MSB	7E
5			7E
6			7E
7		LSB	7E
8	RF Channel	100 kHz step (RXDL1-433) 200 kHz step (RXDL1-868)	6B (433,1 MHz) 75 (868,2 MHz)
9	Tx Power	00 = -10 dBm 01 = -2 dBm 02 = +6 dBm 03 = +10 dBm	00
10	Tx data packet size		1E (30 bytes)
11	Rx data packet size		1E (30 bytes)

The RF Channel is calculated as:

433 MHz working frequency : $\text{Configuration value (decimal)} = (\text{desired RF frequency} - 422.4\text{MHz}) * 10$

868 MHz working frequency : $\text{Configuration value (decimal)} = [(\text{desired RF frequency} / 2) - 422.4\text{MHz}] * 10$

Note : *calculated value must be converted into hexadecimal format.*

The Configuration pin (Pin 14) must be held low (ground) for at least the first byte to change the RXQ2 module into configuration mode. If the Configuration pin is still low at the end of the configuration then the module will send the current configuration back to the host. To retrieve the current configuration without changing any options the host can send a single byte to the module and wait for the response.

It is not necessary to send all configuration bytes to the module, but all data sent must be valid. For example to change the destination address the host may just send four bytes. Configuration data excluded from the end of the data stream will be unchanged. The RXQ2 module will accept a short configuration after a 10ms timeout after the last byte sent to the module, or when the RTS pin goes high. This allows for the host to easily change the destination address of the RF data packet, thus enabling one RXQ2 to send individual data to several different recipient modules.

A destination address of 00000000 will reset the RXQ2 to the default settings shown above.

RF data packets received by the RXQ2 with the embedded destination address which matches the RXQ2

address will be accepted, processed and passed to the host, all of the RF data packets will be ignored.

When configuring the destination or RXQ2 address an incorrect number of bytes for an address will leave the current address unchanged. An invalid Transmitter Power or Packet Size setting will leave the current setting unchanged.

Application information

Connection of the RXQ2 to an RS232 host terminal device such as a PC serial port may easily be achieved using the circuit as below. The 9 way 'D' socket (J1) provides the standard pinout required to connect directly to the serial port of any std PC using a 9 way male/female cable. The MAX3232 (U2) provides level conversion between the RS232 levels on the serial port and the logic levels pins of the RXQ2 module. (note that direct connection of RS232 levels to the module will result in immediate destruction of the device).

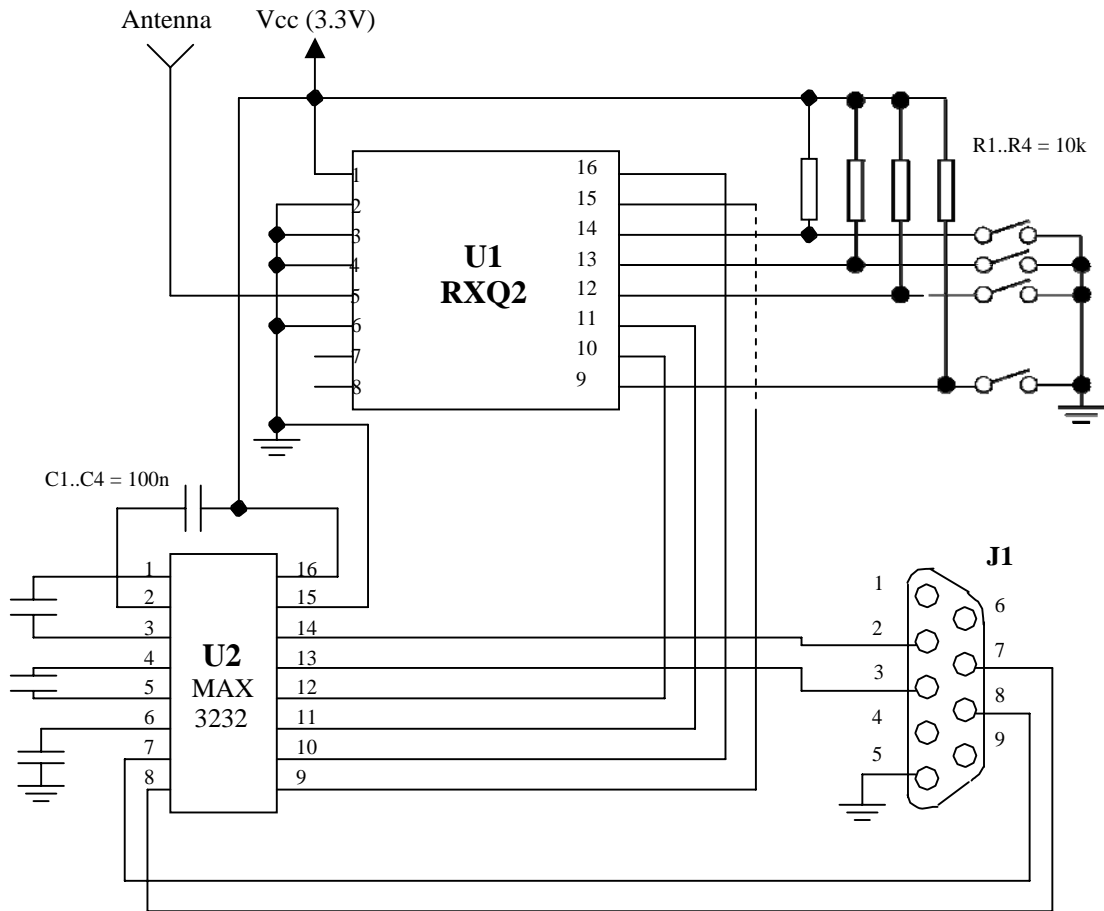

Circuit notes:

- Pins 12 and 13 of the RXQ2 (U1) are pulled high via 10K Ohm resistors, this sets a board rate of 38,400 Baud.
- Pin 9 of RXQ2 is pulled high via 10K Ohm resistor to prevent the RXQ2 from going in to power down mode.
- Pin 14 of RXQ2 is pulled high via 10K Ohm resistor to prevent the module from entering configuration.

If two such circuits are constructed then it will be possible to interconnect two PC's and test out the performance of the hybrids. When both circuits are powered up it will be necessary for them to have others address in the "Destination Address" register.

The RXQ2 is programmed through the same RS232 port that is used for sending/receiving data. An RS232 terminal emulator (such as LABVIEW□) is an ideal tool. To configure the module you can use "RXQ2_Setting.vi" (free download from our web site): for further details on configuration program, see also [RXDL1 radio data link](#) Datasheet.

Antenna Design

The design and positioning of the aerial is as crucial as the module performance itself in achieving a good wireless system range. The following will assist the designer in maximizing system performance. The RF ground pin should be connected to a ground plane which should shield the aerial connection and the PCB layout around the aerial track itself should be such as to give a 50 Ohm impedance. The aerial should be kept as far away from sources of electrical interference as physically possible. The specified power supply decoupling capacitors should be placed close to the module as possible and have direct connections to the relevant pins.

The antenna 'hot end' should be kept clear of any objects, especially any metal as this can severely restrict the efficiency of the antenna to receive power. Earth planes restricting the radiation path of the antenna will also have the same effect.

The best range will be achieved with either a straight piece of wire, rod or PCB track @ $\frac{1}{4}$ wavelength. Increased range may be achieved if this $\frac{1}{4}$ wave antenna is placed perpendicular to and in the middle of a solid earth plane measuring at least 16cm radius. In this case, the antenna should be connected to the module using 50 Ohm coaxial cable and the PCB track layout tips given above should be observed.

Helical Antenna

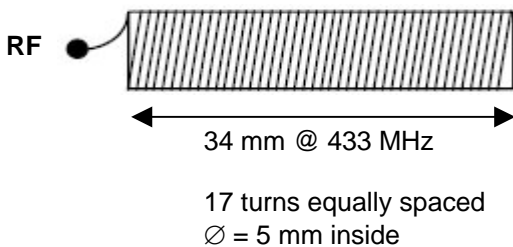

Whip Antenna

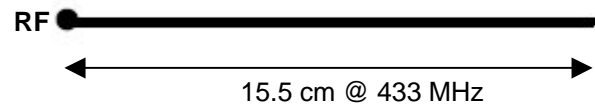

Helical Antenna

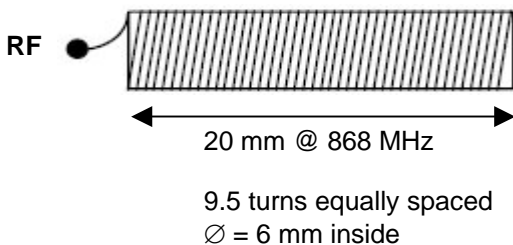

Whip Antenna

