



SENSOR SWITCH

Item.#	RBS3111 Series	Description	TILT SWITCH	Version	V97.0
Page	1 of 10		Date	Sep. 30, 2008	

● APPLICATIONS

1. Tilt Detecting within a 360° radius:
LCD Monitor Rotation
Home Appliance Tilt Off function
2. Slight Vibration Detecting:
Earthquake Alarm



● FEATURES

1. Small size & compact space.
2. Housing made of high insulation plastic material, free from electric conduction and rust problem.
3. Using photo transistors to detect signal makes the signal highly reliable and stable.
4. All plastic material subject to industrial purpose meets with UL94V-0 grade; high temperature and fireproof function.
5. Suitable to IC trigger signal.
6. Suitable to vertical PCB.
7. Tilt Angles: 15°, 20°, 30°, and 45° within a 360° radius.
8. Complete replacement of mercury switch and meet with environmental protection.

● PATENTS

1. TAIWAN Patent NO. 181431
2. CHINA Patent NO. ZL 01 2 60920.X
3. U.S.A. Patent NO. US 6,800,841 B1



SENSOR SWITCH

Item.#	RBS3111 Series	Description	TILT SWITCH	Version	V97.0
Page	2 of 10		Date	Sep. 30, 2008	

● DIMENSIONS / OPERATION / P.C.B. LAYOUT (Unit: mm, Tolerance: $\pm 0.25\text{mm}$)

<p>RBS 31 11 10</p>	<p>Tilt Angle $45^\circ \pm 10^\circ$</p>	<p>P.C.B. Layout (DIP)/Top View</p>
<p>Installation Position</p>	<p>Application Circuit</p>	
	<p>1. $V_{ce}=5V$ 2. $R_D=430\text{ohm}$ 3. $R_L=33K\text{ohm}$</p>	



SENSOR SWITCH

Item.#	RBS3111 Series	Description	TILT SWITCH	Version	V97.0
Page	3 of 10		Date	Sep. 30, 2008	

<p>RBS 31 11 11</p>	<p>Tilt Angle $30^{\circ} \pm 10^{\circ}$</p> <p> ■ Uncertain ($20^{\circ} \sim 40^{\circ}$) ($-20^{\circ} \sim -40^{\circ}$) ▨ Lo district ($0^{\circ} \sim 20^{\circ}$) ($0^{\circ} \sim 20^{\circ}$) □ Hi district ($40^{\circ} \sim 180^{\circ}$) ($-40^{\circ} \sim -180^{\circ}$) </p>	<p>P.C.B. Layout (DIP)/Top View</p>
<p>Installation Position</p>	<p>Application Circuit</p>	
	<p> 1. $V_{ce} = 5V$ 2. $R_D = 430\text{ohm}$ 3. $R_L = 33K\text{ohm}$ </p>	



SENSOR SWITCH

Item.#	RBS3111 Series	Description	TILT SWITCH	Version	V97.0
Page	4 of 10		Date	Sep. 30, 2008	

<p>RBS 31 11 12</p>	<p>Tilt Angle $20^{\circ} \pm 10^{\circ}$</p> <ul style="list-style-type: none"> Uncertain ($10^{\circ} - 30^{\circ}$) ($-10^{\circ} - -30^{\circ}$) Lo district ($0^{\circ} - 10^{\circ}$) ($0^{\circ} - -10^{\circ}$) Hi district ($30^{\circ} - 180^{\circ}$) ($-30^{\circ} - 180^{\circ}$) 	<p>P.C.B. Layout (DIP)/Top View</p>
<p>Installation Position</p>	<p>Application Circuit</p>	
<p>P.C.B.</p>	<ul style="list-style-type: none"> 1. $V_{ce} = 5V$ 2. $R_D = 430\Omega$ 3. $R_L = 33K\Omega$ 	



SENSOR SWITCH

Item.#	RBS3111 Series	Description	TILT SWITCH	Version	V97.0
Page	5 of 10		Date	Sep. 30, 2008	

<p>RBS 31 11 13</p> <p>Cathode Emitter Anode Collector</p>	<p>Tilt Angle $15^\circ \pm 10^\circ$</p> <p>Uncertain (5°-25°) (-5°--25°)</p> <p>Lo district (0°-5°) (0°--5°)</p> <p>Hi district (25°-180°) (-25°-180°)</p>	<p>P.C.B. Layout (DIP)/Top View</p>
<p>Installation Position</p>	<p>Application Circuit</p>	
<p>P.C.B.</p>	<p>1. $V_{ce}=5V$ 2. $R_D=430\text{ohm}$ 3. $R_L=33\text{Kohm}$</p>	

● Device Selection Guide

Input Current (mA)	Operating Voltage (V)
10	5



SENSOR SWITCH

Item.#	RBS3111 Series	Description	TILT SWITCH	Version	V97.0
Page	6 of 10		Date	Sep. 30, 2008	

● Absolute Maximum Rating (Ta=25°C)

Item		Symbol	Rating	Unit
Input	Power Dissipation	Pd	75	mW
	Reverse Voltage	Vr	5	V
	Forward Current	I _F	50	mA
	Peak Forward Current (*1)	I _{FP}	1	A
Output	Collector Power Dissipation	Pc	100	mW
	Collector Current	Ic	20	mA
	C-E Voltage	V _{CEO}	30	V
	E-C Voltage	V _{ECO}	5	V
Operating Temperature		Topr	-25~+85	°C
Storage Temperature		Tstg	-40~+100	°C
Soldering Temperature (*2)		Tsol	260	°C

(*1) tw=100 uSec. 、 T=10 mSec.

(*2) t=5 Sec

● MECHANICAL CHARACTERISTICS

1.	Temperature Range	Operating: -25°C to +85°C Storage: -40°C to +85°C
2.	Pull Force of Terminal	500 gf for 1 minute
3.	Operation Life	30,000 Hours
4.	Humidity	95% RH, 40° C for 96 hrs.
5.	Solder ability	After flux 260±5°C for 5±0.5 seconds 95% coverage



SENSOR SWITCH

Item.#	RBS3111 Series	Description	TILT SWITCH	Version	V97.0
Page	7 of 10		Date	Sep. 30, 2008	

● Electrical Optical Characteristics (Ta=25°C)

Parameter	Symbol	Condition	Min.	Typ.	Max.	Unit
Forward Voltage	V_F	$I_F=20mA$	—	—	1.5	V
Reverse Current	I_R	$V_R=5V$	—	—	10	μA
Peak Wavelength	λ_p	$I_F=10mA$		940		nm
Dark Current	I_D	$V_{CE}=10V$	—	—	2	μA
C-E Saturation Voltage	$V_{CE(sat)}$	$I_C=0.25mA$ $I_F=20mA$	—	—	0.4	V
Light Current	I_L	$V_{CE}=5V$ $I_F=20mA$	0.5	5	—	mA
Rise Time	T_r	$I_C=0.8mA$	—	5	—	μsec
Fall Time	T_f	$V_{CC}=30v$ $R_L=1K\Omega$	—	5	—	μsec

● BILL OF MATERIAL

1.	Housing	Class-Fiber Polyamide, UL 94-0
2.	Base	Class-Fiber Polyamide, UL 94-0
3.	Ball	Stainless Steel
4.	Infrared Emitting Diodes	
5.	Silicon Photo Transistors	
6.	Inside part	Copper Alloy, Nickel Plated



SENSOR SWITCH

Item.#	RBS3111 Series	Description	TILT SWITCH	Version	V97.0
Page	8 of 10		Date	Sep. 30, 2008	

● Typical Electrical / Optical Characteristics Curves (Ta=25°C)

Fig.1 Power Dissipation vs. Ambient Temperature

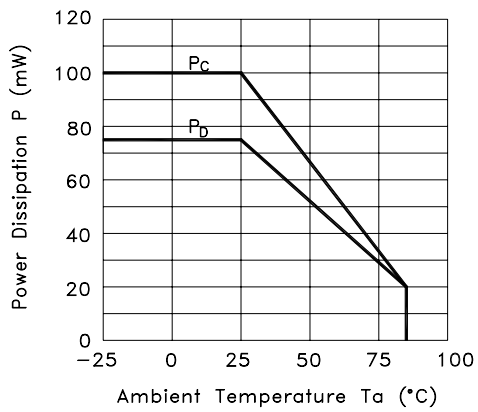

Fig.2 Forward Current vs. Forward Voltage

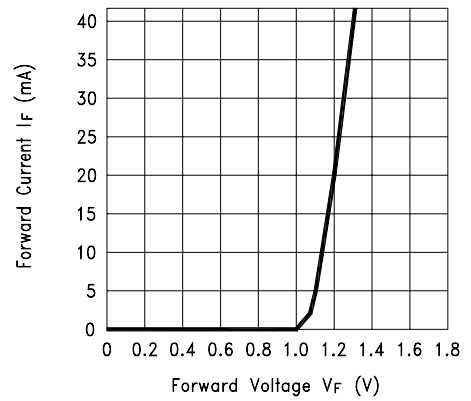

Fig.3 Collector Current vs. Collector-emitter Voltage

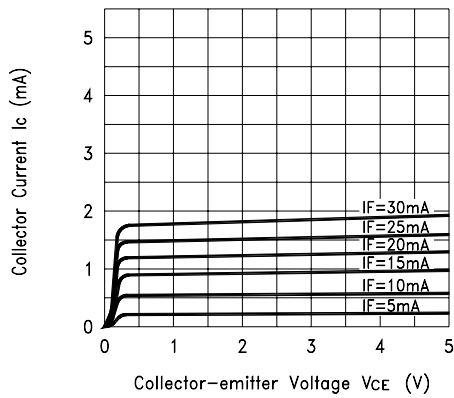
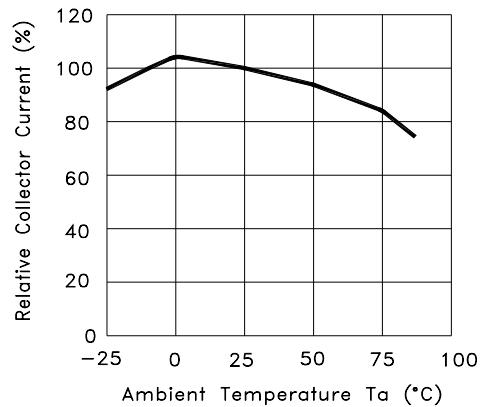

Fig.4 Collector Current vs. Ambient Temperature





SENSOR SWITCH

Item.#	RBS3111 Series	Description	TILT SWITCH	Version	V97.0
Page	9 of 10		Date	Sep. 30, 2008	

Fig.5 Collector-emitter Saturation Voltage vs. Ambient Temperature

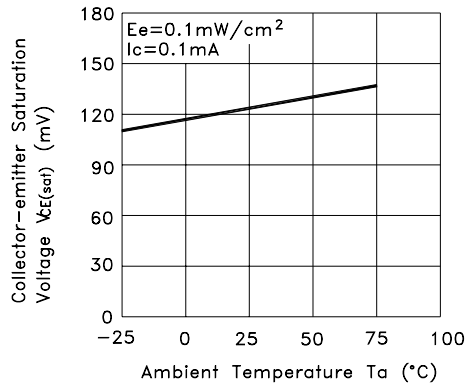

Fig.6 Response Time vs. Load Resistance

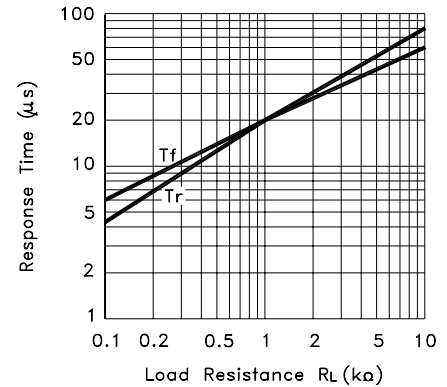
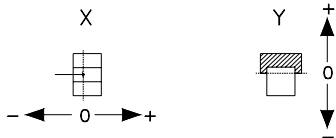
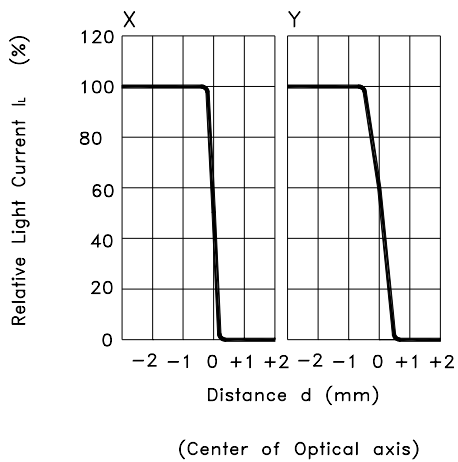
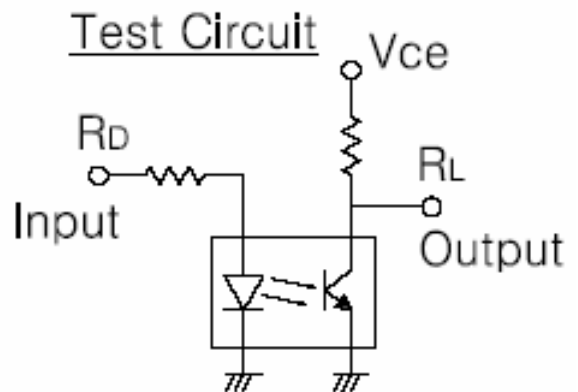

Fig.7 Sensing Position Characteristics (Typical)



Test Circuit for Response Time





SENSOR SWITCH

Item.#	RBS3111 Series	Description	TILT SWITCH	Version	V97.0
Page	10 of 10		Date	Sep. 30, 2008	

● PACKAGE

	Part Number	Package	Quantity	Total	Size
1.	RBS311110	PE Bag	250 pcs	250 pcs	12.7 x 17.8 (cm)
	RBS311111	Inner Box	8 PE Bag	2,000 pcs	36 x 20 x 9 (cm)
	RBS311112				
	RBS311113	Carton	3 Boxes	6,000 pcs	36 x 28 x 23 (cm)
2.	RBS311110	IC tube	48 pcs	48 pcs	52.5 x 1 x 1.75 (cm)
	RBS311111	Inner Box	84 tubes	4,032 pcs	54 x 13 x 13 (cm)
	RBS311112				
	RBS311113	Carton	4 Boxes	16,128 pcs	55 x 29 x 29 (cm)

* Minimum Order Quantity: One Bag / One Box (84 tubes)

● NOTE

1. For the continued product improvement as one of the company policy, specifications may change or update without notice. The latest information can be obtained through our sales offices. Normally, all products are supplied under our standard conditions.

● PRECAUTIONS FOR USE

1. The product is used mainly in electronic devices such as automotive devices, visual devices, home electrical appliances, information devices and communication settings. If the products is intended to be used for other endurance equipments requiring higher safety and reliability such as life support system, space and aviations devices, disaster and safety system, it's necessary to make verification of conformity or contact us for the details before using.
 2. Don't try to clean the switch with a solvent or similar substance after the soldering process.
 3. The switch might be damaged if using the water-soluble flux.
-