

# Multi-Component Sensors

## 50004

### TIRE UNIFORMITY FORCE SENSOR

This sensor measures two forces applied at right angles to the sensor. It is used in tire uniformity grading (TUG) and various tire testing machines. In these applications, a "road wheel" is supported on an axle mounted between two sensors allowing both normal and lateral forces to be measured. Lateral forces are often eliminated from tires in these machines by grinders which remove rubber from the tire carcass in defined areas.



### SPECIFICATIONS

Capacity.....	See chart
Overload capacity.....	
Side.....	200% of F.S.
Radial.....	150% of F.S.
Output at full scale.....	See chart
Non-linearity.....	0.10% of F.S.
Hysteresis.....	0.10% of F.S.
Zero balance.....	1% of F.S.
Compensated temperature.....	70 to 170°F
Useable temperature.....	-65 to +250°F
Temperature effect on zero.....	0.002% of F.S./°F
Temperature effect on span.....	0.002% of Rdg./°F
Bridge resistance.....	350 Ohms
Excitation voltage, maximum.....	20 Vdc
Cross talk.....	0.25% of F.S.
Natural frequency, minimum.....	40 Hz

### DIMENSIONS

MODEL	RADIAL (FX)		SIDE (FY)	
	CAPACITY LBS	OUTPUT (mV/V) + .25%	CAPACITY LBS	OUTPUT (mV/V) + .25%
50004-301-301	300	2.0	300	2.0
50004-501-501	500			
50004-102-501	1000			
50004-202-501	2000			
50004-152-501	1500			
50004-152-751	1500		750	
50004-402-102	4000	1.5	1000	1.5

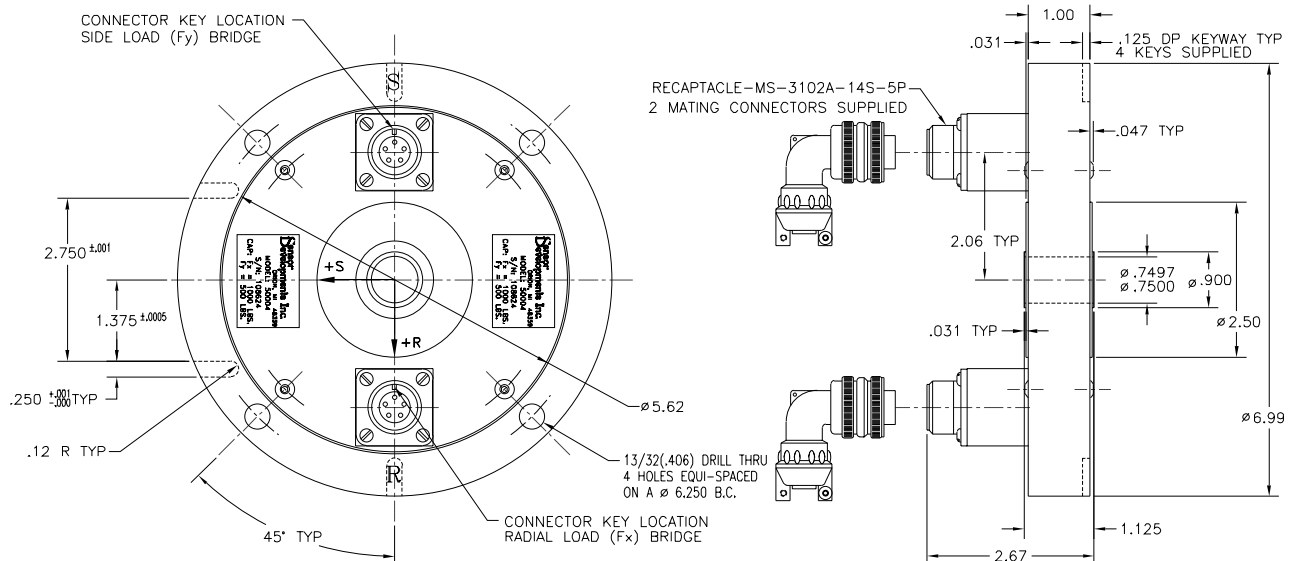

DWG



ORDER TOLL FREE 1-888-SENSOR-1