

XS-ZTR (extreme environment LVDT)

Nuclear Radiation Resistant LVDT

The XS-ZTR Series The XS-ZTR Series LVDT is designed for measuring displacement at very high and very low, cryogenic temperatures. The XS-ZTR operates continuously at 550 °C and will survive 650 °C for several hours. The XSZTR is also designed to perform within specification after exposure to a total integrated flux of 10^{11} rads gamma or 3×10^{20} NVT.

The XS-ZTR is made exclusively from inorganic materials, principally metals and ceramics. Windings are of ceramic insulated precious metal alloys; joints are welded or brazed with high temperature alloys. Leads are sheathed in stainless steel. Conductors are nickel with magnesium oxide insulation. Materials are selected to have compatible expansion coefficients in order to minimize induced thermal stresses. As most inorganic insulations are hygroscopic the entire coil assembly is hermetically sealed into a stainless steel shell. This process prevents moisture accumulation and insulation leakage. It also seals out hostile surrounding media while permitting the core to move freely. The cable can be terminated by a sealed header or connector when required. For moderate temperature and radiation applications, consider using the HR or HCA series LVDT with the MRR (mildly radiation resistant - 080 option).

Radiation Resistance

Certain applications require resistance to a combination of gamma radiation, neutron radiation and high temperature. Before considering detailed specifications and suitability for a particular application a review of some working definitions and equivalents is in order:

nvt = integrated flux or fluence

= neutron density x velocity x time

= $n/m^3 \times m/s \times s$

= n/m^2

rad = radiation absorbed dose

= radiation that will deposit 100 ergs per gram

$n/cm^2 = 4.17 \times 10^{-9}$ rads

$n/cm^2 = 4.17 \times 10^{-7}$ ergs/gm

1 Gray (gy) = 100 rad absorbed dose

1 rad/hr = approximately 7×10^8 neutrons/ m^2s^2

All radiation produces some damage, therefore, the issue becomes how much radiation and what kind of radiation can an object sustain while maintaining its operation specification. At best, this can only be an estimate.

When radiant energy falls on an object, equal amounts of energy from different sources may result in greatly differing amounts of damage depending on the form of radiation, i.e. gamma rays, neutrons, etc. These different sources may also result in qualitatively different kinds of damage. One method to quantify these differences is to determine the rate of radiation that a unit can withstand without instantaneous and unacceptable damage. Another method is to determine the total integrated flux that can be absorbed before "wear-out" damage from radiation occurs. The distinction between rate of flux and total integrated flux must be kept clearly in mind.

There is no direct relationship between neutron fluence and gamma radiation. If we assume equal energy dissipation from differing sources, the energy absorbed by the unit will vary with its absorption cross section. If we try to equalize damage, there is even more uncertainty because of the qualitative differences of the damage caused by various forms of radiation.



FEATURES

- Withstands Total Integrated Neutron Flux Levels to 3×10^{20} NVT
- Withstands total integrated radiation of 10^{11} rads or 10^9 gray
- Suitable for Continuous Operation from -320° to 1022° F (-195° to 550° C)
- Survives Non-Operating Temperatures up to 1200° F (650° C)
- Special Temperature Calibrations Available
- Calibration Certificates Supplied with All Models

APPLICATIONS

- Material Testing in Pressurized Autoclaves
- Nuclear Reactor Containment Vessel Bolt Tension
- Cryogenic Medicine
- Space Research
- Jet Engine Thrust Vectoring Feedback
- Roll Gap On Steel Hot Strip and Slabbing Mills

Common Specifications

Input Voltage	3 V nms nominal)
Frequency Range	400 Hz to 5000 Hz
Operating Temperature Range	-320° to 1022° F (-195° to 550° C)
Survival Temperature Range	-450° to 1200° F (-270° to 650° C)
Operating Pressure	2500-psi max (175-Bar)
Null Voltage	<0.5% full scale output
Shock Survival	10 g for 11 msec
Vibration Tolerance	10 g up to 2 kHz
Coil Form Material	Ceramic
Housing Material	AISI 304 Series Stainless Steel
Lead Wires	28 AWG solid nickel, MgO insulated, 72 inches (180cm) long (nominal): 3/16 inch (4.75mm) diameter stainless steel sheath, 1/2 inch (12.7mm) minimum bend radius

XS-ZTR (extreme environment LVDT)

dimensions

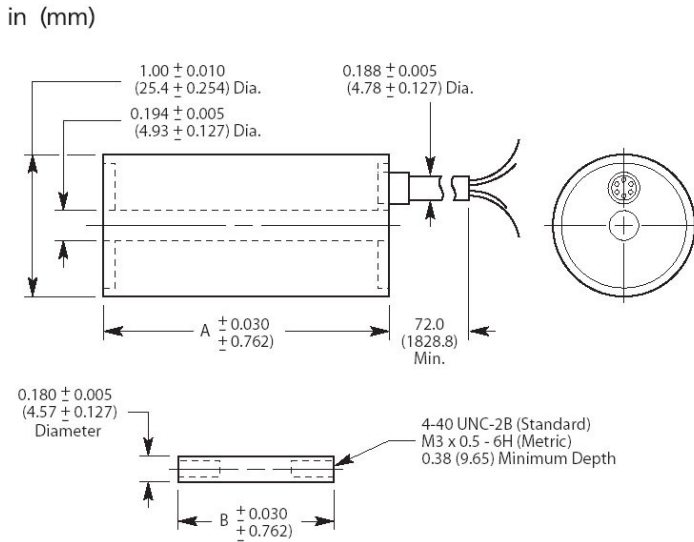

wiring

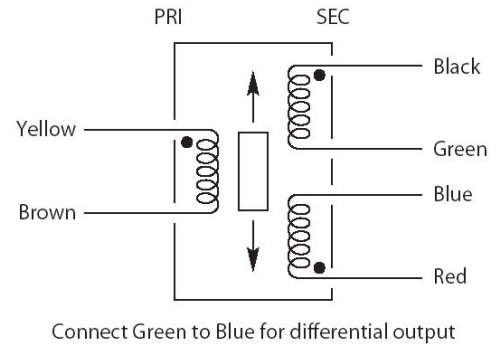

Standard termination is a multiple conductor 6-foot (1.8m) long, 3/16 inch (4.75 mm) diameter swagged stainless steel cable. Other lengths and diameters are available on special order. A frequently specified alternative termination is a pair of 2-conductor 1/16 inch (1.6mm) diameter stainless steel sheathed cables. These are particularly suitable for applications where the cables are routed through an arduous path within the reactor.

Performance and electrical specifications

XS-ZTR Series Model Number	Nominal Linear Range		Linearity (±% Full Range)	Sensitivity mV out/V in Per		Impedance (Ohms)		Phase Shift Degrees
	inches	mm		100	0.001 in	mm	Pri	
100 XS-ZTR	±0.100	±2.54	0.5	1.3	51	95	250	-8
250 XS-ZTR	±0.250	±6.35	0.5	0.3	12	100	80	+20

Mechanical Specifications

XS-ZTR Series Model Number	Body		Weight		Core		Dimensions		
	oz	gm	oz	gm	A (Body)		B (Core)		
					in	mm	in	mm	mm
100 XS-ZTR	2.29	65	0.09	2.5	2.51	63.8	1.35	34.3	
250 XS-ZTR	4.06	115	0.28	8.0	3.83	97.2	1.35	34.3	

*with 6-foot cable

The information in this sheet has been carefully reviewed and is believed to be accurate; however, no responsibility is assumed for inaccuracies. Furthermore, this information does not convey to the purchaser of such devices any license under the patent rights to the manufacturer. Measurement Specialties, Inc. reserves the right to make changes without further notice to any product herein. Measurement Specialties, Inc. makes no warranty, representation or guarantee regarding the suitability of its product for any particular purpose, nor does Measurement Specialties, Inc. assume any liability arising out of the application or use of any product or circuit and specifically disclaims any and all liability, including without limitation consequential or incidental damages. Typical parameters can and do vary in different applications. All operating parameters must be validated for each customer application by customer's technical experts. Measurement Specialties, Inc. does not convey any license under its patent rights nor the rights of others.

ordering info

Specify the XS-ZTR followed by the desired option number(s) ordered together.

Ordering Example:
Model Number 100 XS-ZTR-006 is an XS-ZTR Series LVDT with a ±0.100 range (100XS-ZTR) with a Metric thread core (006)

XS-ZTR model

100 XS-ZTR
250 XS-ZTR

options

Number	Description
006	Metric Thread Core