



# GENERAL INFORMATION SELECTOR CHART

Series	Series Types	Enclosure	Contacts		Nominal Coil Voltage or Current	Operating Power at P.I. (mW)	Applicable Specification Approvals							
			Arrangement	Rating			MILITARY		CECC					
							Mil-PRF-39016/	Mil-PRF-28776/	16101-	16207-				
MA	MA	TO-5	DPDT	1A / 28 Vdc	5...30,0 Vdc	130	9							
	MA-D				5...26,5 Vdc		15							
	MA-DD						20							
	MA-T							1						
MA2		TO-5	DPDT	1A / 28 Vdc	5...30,0 Vdc	130			003					
MCA		TO-5	DPDT	2A / 28 Vdc	5...26,5 Vdc	150								
MS	MS	TO-5	DPDT	1A / 28 Vdc	5...48,0 Vdc	60	11							
	MS-D						16							
	MS-DD						21							
	MS-T							3						
MS2		TO-5	DPDT	1A / 28 Vdc	5...48,0 Vdc	60			004					
1MA	1MA	TO-5	SPDT	1A / 28 Vdc	5...26,5 Vdc	100	7							
	1MA-D						23							
	1MA-DD						24							
	1MA-T							5						
1MA1		TO-5	SPDT	1A / 28 Vdc	5...26,5 Vdc	100			005					
1MS	1MS	TO-5	SPDT	1A / 28 Vdc	5...40,0 Vdc	50	10							
	1MS-D						25							
	1MS-DD						40							
	1MS-T						50		4					
1MS1		TO-5	SPDT	1A / 28 Vdc	5...40,0 Vdc	50			006					
	MGA	CUBIC .100GRID	DPDT	1A / 28 Vdc	5...26,5 Vdc	130	17							
	MGA-D						18							
MGA-DD	150													
MGAE	MGAE	CUBIC .100GRID	DPDT	1A / 28 Vdc	5...28,0 Vdc	130				801				
	MGAE-D													
	MGAE-DD						150							
MGA2	MGA2/D2	CUBIC	DPDT	1A / 28 Vdc	5...28,0 Vdc	140			007					
MGS	MGS	CUBIC .100GRID	DPDT	1A / 28 Vdc	5...48,0 Vdc	60	41							
	MGS-D						42							
	MGS-DD						43							
MGSE	MGSE	CUBIC .100GRID	DPDT	1A / 28 Vdc	5...48,0 Vdc	60				802				
	MGSE-D													
	MGSE-DD													
MGS2	MGS2/D2	CUBIC	DPDT	1A / 28 Vdc	5...48,0 Vdc	60			008					
12K		1/2 CC	DPDT	2A / 28 Vdc	5...26,5 Vdc	250	6							
2K		1/2 CC	DPDT	2A / 28 Vdc	5...48,0 Vdc	250								
2K6600		1/2 CC	DPDT	2A / 28 Vdc	5...48,0 Vdc	250				007.014.021				
							MILITARY Compliance							
							Mil-R-39016/	Mil-R-5757/						
2K7940		1/2 CC	DPDT	2A / 28 Vdc	6...26,5 Vdc	250	22							
KA	2KA	1/2 CC	DPDT	2A / 28 Vdc	5...48,0 Vdc	100								
HA	2HA	1/2 CC	DPDT	5A / 28 Vdc	5...48,0 Vdc	300								
B	2B	CC	DPDT	2A / 28 Vdc	6...76,0 Vdc	250								
	2BR				26,5...115 Vac		370							
2B6660		CC	DPDT	3A / 28 Vdc	6...76,0 Vdc	250			008					
2B7506		CC	DPDT	2A / 28 Vdc	6...26,5 Vdc	250			10					
	BS						CC	DPDT	2A / 28 Vdc	6...26,5 Vdc	100			
	2BSA											CC	SPDT	2A / 28 Vdc
1BSK	CC	DPDT	2A / 28 Vdc	3,2...70,6mA	40									
2BSK						CC	DPDT	2A / 28 Vdc	4,0...89,2mA	40				
BN	1BN	CC	SPDT	5A / 28 Vdc	6...76,0 Vdc						280			
	2BN					CC	DPDT	2A / 28 Vdc	4,0...90,0mA	40				
2BC7201		CC	DPDT	2A / 28 Vdc	4,0...90,0mA						40		13	
BCN	1BCN	CC	SPDT	5A / 28 Vdc	6...40,0 Vdc	80								
	2BCN						CC	DPDT	2A / 28 Vdc	6...115 Vdc	400			
4B		CC	4PDT	2A / 28 Vdc	6...115 Vdc	400								
T	2T	CC	DPDT	10A / 28 Vdc	6...115 Vdc	500								
	2TR				115 Vac									
TN	2TN	CC	DPDT	15A / 28 Vdc	6...115 Vdc	500								
	2TNR				115 Vac									
2T7188		CC	DPDT	10A / 28 Vdc	6...120 Vdc	500			23					
RFK	RFK	1/2 CC	SPDT	2A / 28 Vdc	6...26,5 Vdc	250								
	2RFK						CC	DPDT	2A / 28 Vdc	6...76,5 Vdc	250			
RFB	RFB	CC	SPDT	2A / 28 Vdc	6...76,5 Vdc	250								
	2RFB						CC	DPDT	2A / 28 Vdc	4,0...89,2 mA	40			
RFBC	RFBC	CC	SPDT	2A / 28 Vdc	4,0...89,2 mA	40								
	2RFBC						CC	DPDT	1A / 28 Vdc	5,0...30,0 Vdc	260			
4MA		CC	4PDT	1A / 28 Vdc	5,0...30,0 Vdc	260								
4MS		CC	4PDT	1A / 28 Vdc	5,0...48,0 Vdc	120								



# HALF SIZE CRYSTAL CAN RELAY 5 AMPERE DPDT

Series  
HA

## Product Description

A proven variation of our standard half size crystal can relay incorporates improved current carrying paths to provide 5 ampere switching.

The design is supported by our standard qualified military relays and their continued testing programs, together with the latest metallurgical innovations in contact materials and current carrying members. Reliability, product consistency and low cost are maintained through our volume production techniques.

The following construction features ensure the highest reliability in extreme environments:

- All welded relay construction
- Cleaning and sealing techniques ensures maximum internal cleanliness
- 5 Amp. switching
- 2 form C, DPDT contacts, special metal alloy with gold plating
- Frame, armature designs and force / mass ratio provides exceptional immunity to shock and vibration.

## Series Type

- 2HA 2 form C, DPDT

## Environmental and Physical Specifications

Temperature (Ambient)	-65°C to +125°C
Shock	100 g's, 6 msec.
Vibration (sinusoidal)	20 g's, 10 to 2000 Hz
Acceleration	30 g's
Sealing	All welded, Hermetic
Weight	0,35 oz. (10,0 grams) max.

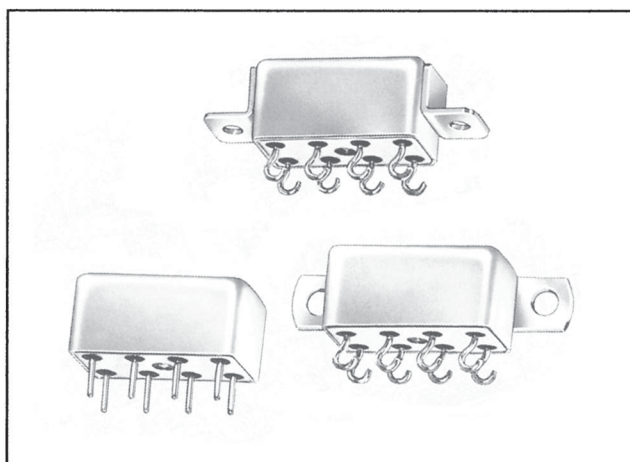

## Electrical Characteristics (over the Temperature range, unless otherwise noted)

Coil Data	See Typical Characteristics chart		
Contact Rating	Type load	Contact Load	Cycles min.
(Note : All ratings with grounded case)	Resistive	5 Amp / 28 Vdc	100.000
		1 Amp / 115 Vac, 400 Hz	100.000
		0.3 Amp / 115 Vac, 60 Hz	100.000
	Inductive	10A / 28 Vdc	100
		0.75 Amp / 28 Vdc (200 mH)	100.000
Overload			
Contact Resistance	0,05 ohm max. initial		
Operate Time	4,0 msec. max. at 25 °C		
Release Time	3,0 msec. max. at 25 °C		
Contact Bounce	3,0 msec. max. at 25 °C		
Dielectric Strength	1000 Vrms min., 60 Hz, all points, 500 Vrms min. between open contacts and coil to case, at sea level		
Insulation Resistance	1000 megohms min. all points at 500 Vdc		
Intercontact Capacitance	2.5 pF Between contact		
Sensitivity	300 milliwatts at pick-up, 1,4 milliwatts at nominal rated coil voltage, at 25 °C		

Figure 1 - Operate & Release Time curves, vs. Applied Voltage

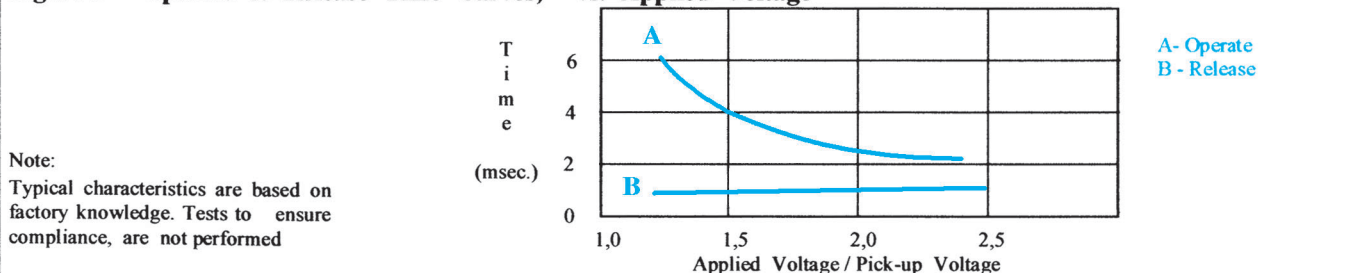



# HALF SIZE CRYSTAL CAN RELAY 5 AMPERE DPDT

Series  
HA

## Typical Characteristics (over the Temperature range, unless otherwise noted)

Voltage Code	Coil Voltage Vdc		Coil Resistance ohms ± 10% at 25 °C	Pick-up Vdc Max. at 25 °C	Drop-out Vdc Min. at 25 °C
	Nominal	Max.			
105	5	6	18	3,6	0,25
106	6,0	7,2	40	3,5	0,3
112	12,0	14	150	7,0	0,7
124	24	29	400	17,0	1,4
126	26,5	32	600	13,5	1,5
136	36	43	900	26,0	2,2
148	48	57	1600	34,0	2,8

### Terminal Styles

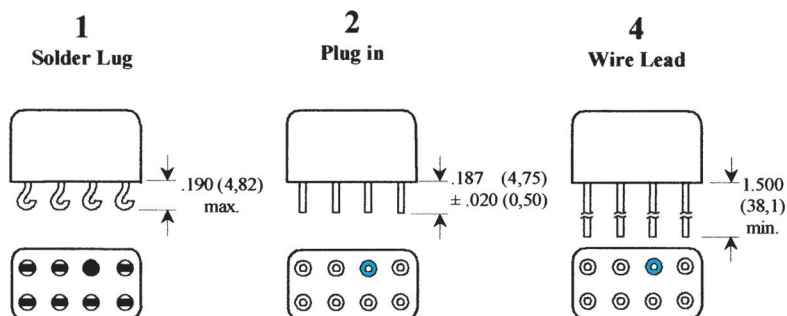

Note :

- Dimensions are shown in inches (millimetres)

- Terminal spacing is .200 (5,08). Terminal diameter is .030 (0,76) + .003 (0,07) - .002 (0,05)

### Schematic Diagram

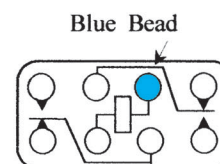

Note :

Schematic is viewed from terminals

### Mounting Styles

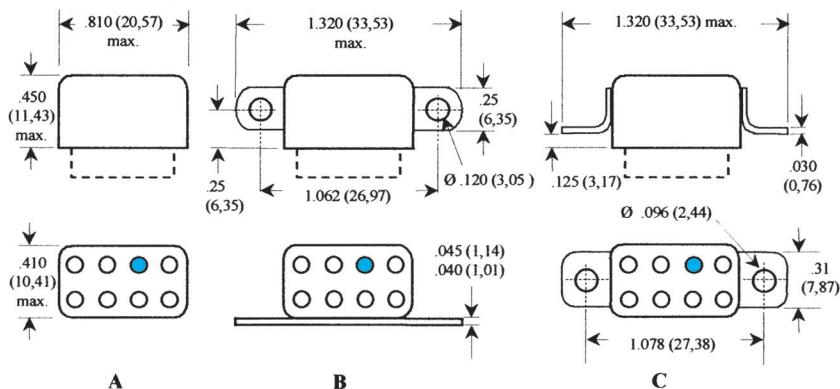

Note : Dimensions are shown in inches (millimetres)

### Insulating Pad

Relays can be supplied with an insulating pad epoxied to the relay header, to prevent the possible shorting of printed circuit board land lines and to facilitate circuit board cleaning. To order relay with pad add. **P** to part Number. Example : **2HA-2A-126 P**

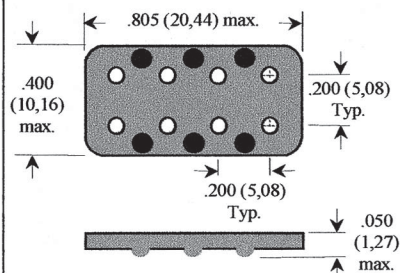

Note :

Dimensions are shown in inches (millimetres)

### How to Order, (Part Numbering System)

