

JIN ZON ENTERPRISE CO., LTD.

4F-3, No. 171, Sec. 2, Chang An E. Rd.,
 Taipei, Taiwan, R. O. C.
 TEL: 886-2-27111093~5
 FAX: 886-2-27310902
 E-mail: jinzon@ms2.hinet.net
 Http:// www.jinzon.com.tw/

Reed relays type K-32/Nx1

This product is in accordance with RoHs

Reed relays with 1 to 4 form A contacts
 (normally open) for PCB's.

PARAMETERS	Unit	TYPE
		K-32/Nx1

1. CONTACT PARAMETERS

Switching power	max	W, VA	60
Switching voltage	max	V_{DC}	200
		V_{AC}	230
Switching current	max	A	3
Contact resistance	max	mA	150
Life expectancy at 60V, 1A		operations	$7,5 \times 10^6$

2. RELAY PARAMETERS

Operating voltage range		V	see p.
Coil resistance		A	see p.
Operate time incl. bounce time for: K-32 / 1 x 1 K-32 / 2 x 1 K-32 / 3 x 1 K-32 / 4 x 1	max	ms	2,5
			3,5
			4,5
			5,5
Release time	max	ms	1
Test voltage, : contact contact/ contact contact/ coil contact/ shield coil/ shield	min	V_{AC}	400
			500
			500
			500
			500
Insulation resistance	min	A	10^9
Admissible ambient temperature			$-40^{\circ}C \div 70^{\circ}C$

3. LIST OF COILS AND OPERATING VOLTAGE RANGE

Symbol of relay	Contact arrangement	Index No	Coil resistance R_N [A] $t = 20^{\circ}C$	Supply voltage, $t = 20^{\circ}C$		
				U_N [V]	U_{MIN} [V]	U_{MAX} [V]
K-32/1x1	1 form A	8-4441-659-1	$180 \pm 10\%$	6	3,6	23,0
K-32/2x1	2 form A	8-4441-661-1	$140 \pm 10\%$		3,9	21,5
K-32/3x1	3 form A	8-4441-662-1	$75 \pm 10\%$		4,4	16,8
K-32/4x1	4 form A	8-4441-663-1	$45 \pm 10\%$		4,2	14,0
K-32/1x1	1 form A	8-4441-659-2	$700 \pm 10\%$	12	7,2	45,4
K-32/2x1	2 form A	8-4441-661-2	$500 \pm 10\%$		7,8	40,6
K-32/3x1	3 form A	8-4441-662-2	$250 \pm 10\%$		8,8	30,7
K-32/4x1	4 form A	8-4441-663-2	$170 \pm 10\%$		9,0	27,2
K-32/1x1	1 form A	8-4441-659-3	$2500 \pm 15\%$	24	15,0	83,4
K-32/2x1	2 form A	8-4441-661-3	$2000 \pm 15\%$		16,2	79,0
K-32/3x1	3 form A	8-4441-662-3	$1000 \pm 10\%$		17,5	61,4
K-32/4x1	4 form A	8-4441-663-3	$760 \pm 10\%$		18,9	57,6
K-32/1x1	1 form A	8-4441-659-4	$10000 \pm 15\%$	48	30,0	166,8
K-32/2x1	2 form A	8-4441-661-4	$6200 \pm 15\%$		30,0	139,0
K-32/3x1	3 form A	8-4441-662-4	$3000 \pm 15\%$		36,0	103,4
K-32/4x1	4 form A	8-4441-663-4	$2200 \pm 15\%$		35,4	95,2

4. DIMENSIONS AND TERMINAL ARRANGEMENTS

K-32/Nx1

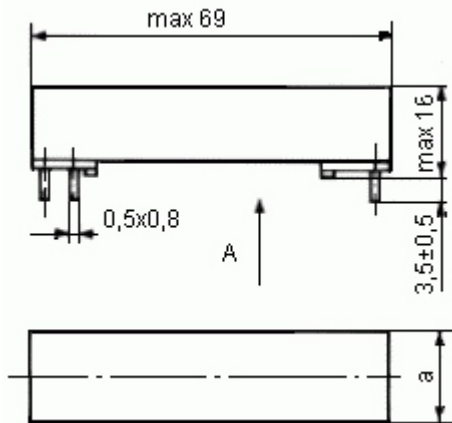

Reed relay	Dimension "a" (max)
K-32/1x1	16,5 mm
K-32/2x1	22,5 mm
K-32/3x1	28 mm
K-32/4x1	33,5 mm

View from the bottom side of relay

$m=2,5$

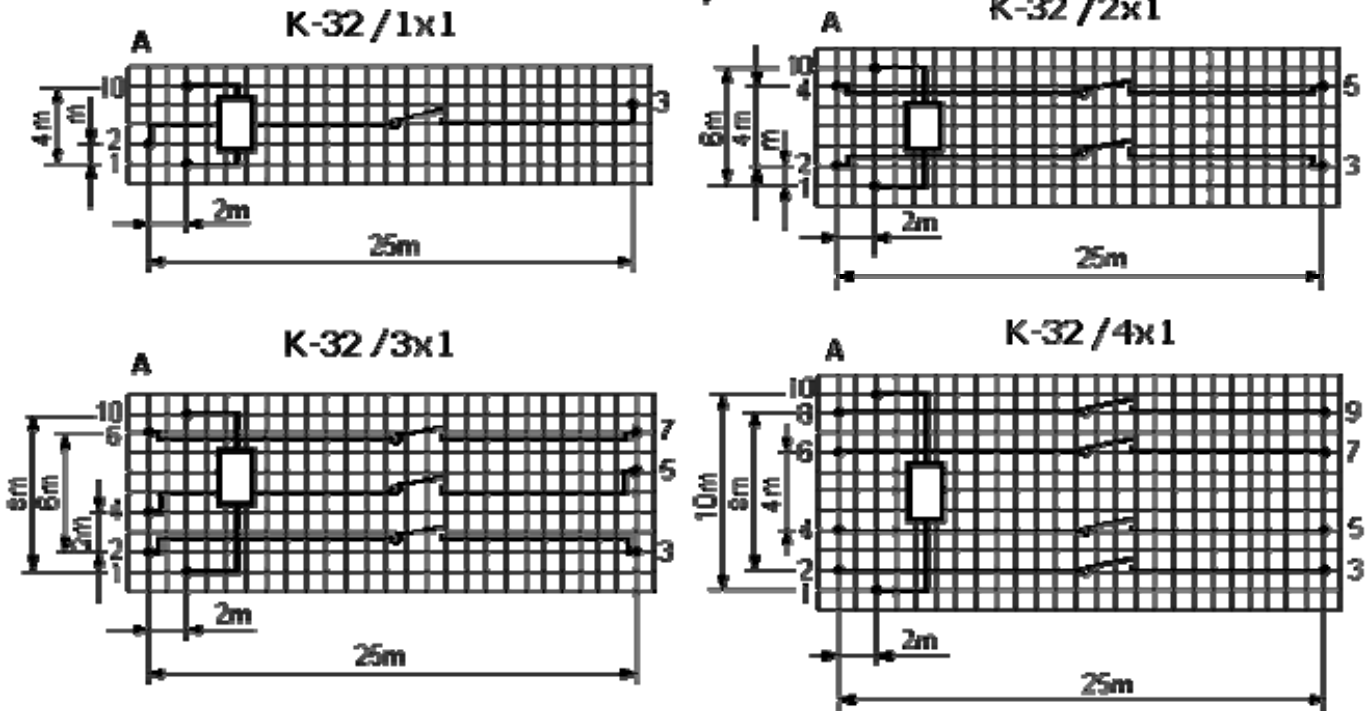

Ordering Information

When ordering relay please specify:

- symbol of relay
- index number

Recommendation for users

When mounting into printed circuit boards, it is advisable to observe the following points to avoid damage to the relays:

- the time of continuous heating of terminals during soldering should not exceed 5 s,
- the soldering iron should not press on terminals during soldering,
- the relays should not be mounted near sources of strong magnetic fields, e.g. transformers, permanent magnets etc.,
- the relays should operate at nominal supply voltages.

JIN ZON ENTERPRISE CO., LTD. 4F-3, No. 171, Sec. 2, Chang An E. Rd., Taipei, Taiwan, R. O. C. TEL: 886-2-27111093~5 FAX: 886-2-27310902 E-mail: jinzon@ms2.hinet.net Http:// www.jinzon.com.tw/	Reed relays type K-32/Nx21 This product is in accordance with RoHs
	Reed relay K-32 with 1 or 2 form C contacts (changeover) for PCB's.

PARAMETERS	Unit	TYPE
		K-32/Nx21

1. CONTACT PARAMETERS

Switching power	max	W, VA	16
Switching voltage	max	V_{DC}	110
		V_{AC}	200
Switching current	max	A	1
Contact resistance	max	mA	200
Life expectancy at 24V, 0,2A		operations	1×10^6

2. RELAY PARAMETERS

Operating voltage range		V	see p.
Coil resistance		A	see p.
Operate time incl. bounce time for:	max	ms	K-32 / 1 x 21 2,5
			K-32 / 2 x 21 4,0
Release time	max	ms	2,5
Test voltage,:	min	V_{AC}	contact 400
			contact/ contact 500
			contact/ coil 500
			contact/ shield 500
			coil/ shield 500
Insulation resistance	min	A	10^9
Admissible ambient temperature			$-40^{\circ}C \div 70^{\circ}C$

3 LIST OF COILS AND OPERATING VOLTAGE RANGE

Symbol of relay	Contact arrangement	Index No	Coil resistance R_N [A] $t = 20^{\circ}C$	Supply voltage, $t = 20^{\circ}C$		
				U_N [V]	U_{MIN} [V]	U_{MAX} [V]
K-32/1x21 K-32/2x21	1 changeover 2 changeover	8-4441-705-1 8-4441-706-1	$180 \pm 10\%$ $95 \pm 10\%$	6	3,8 4,0	23,0 17,7
K-32/1x21 K-32/2x21	1 changeover 2 changeover	8-4441-705-2 8-4441-706-2	$700 \pm 10\%$ $370 \pm 10\%$	12	7,6 8,0	45,4 34,9
K-32/1x21 K-32/2x21	1 changeover 2 changeover	8-4441-705-3 8-4441-706-3	$2500 \pm 15\%$ $1500 \pm 10\%$	24	15,8 16,0	83,4 70,4
K-32/1x21 K-32/2x21	1 changeover 2 changeover	8-4441-705-4 8-4441-706-4	$10000 \pm 15\%$ $5000 \pm 15\%$	48	31,6 33,0	166,8 124,9

4. DIMENSIONS AND TERMINAL ARRANGEMENTS

K-32/Nx21

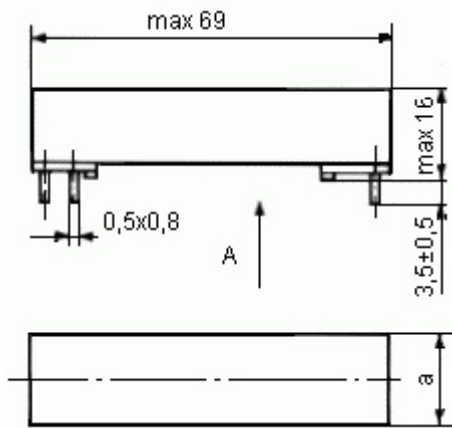

Reed relay	Dimension a
K-32/1x21	16,5 mm
K-32/2x21	22,5 mm

View from the bottom side of relay

$m=2,5$

K-32/1x21

K-32/2x21

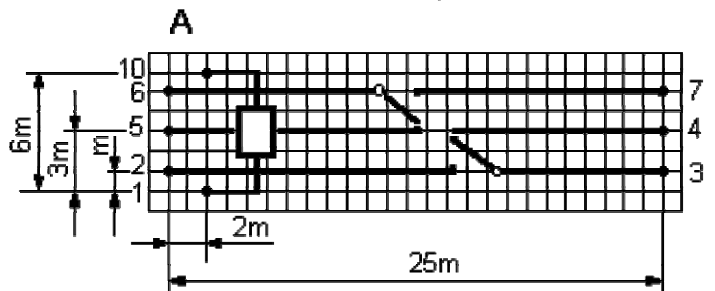
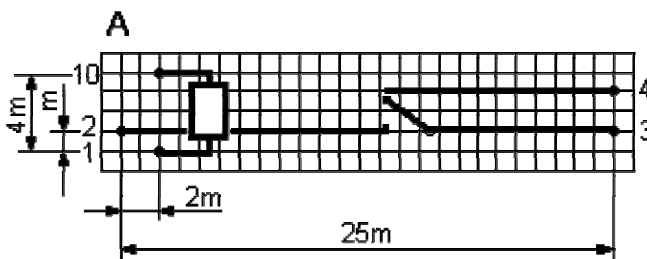

Ordering Information

When ordering relay please specify:

- symbol of relay
- index number

Recommendation for users

When mounting into printed circuit boards, it is advisable to observe the following points to avoid damage to the relays:

- the time of continuous heating of terminals during soldering should not exceed 5 s,
- the soldering iron should not press on terminals during soldering,
- the relays should not be mounted near sources of strong magnetic fields, e.g. transformers, permanent magnets etc.,
- the relays should operate at nominal supply voltages.

JIN ZON ENTERPRISE CO., LTD.

4F-3, No. 171, Sec. 2, Chang An E. Rd.,
Taipei, Taiwan, R. O. C.
TEL: 886-2-27111093~5
FAX: 886-2-27310902
E-mail: jinzon@ms2.hinet.net
Http:// www.jinzon.com.tw/

Reed relays type K-32/Nx2

This product is in accordance with RoHS

Reed relay K-32 with 1 or 2 form B contacts
(normally closed) for PCB's.

PARAMETERS	Unit	TYPE
		K-32/Nx2

1. CONTACT PARAMETERS

Switching power	max	W, VA	60
Switching voltage	max	V _{DC}	200
		V _{AC}	230
Switching current	max	A	1
Initial contact resistance	max	mA	150
Life expectancy at 60V, 1A		operations	7,5x10 ⁶

2. RELAY PARAMETERS

Operating voltage range		V	see p.	
Coil resistance		A	see p.	
Operate time for:	max	ms	2,5	
			3	
Release time	max	ms	1,5	
Test voltage.:	min	V _{AC}	contact	400
			contact/ contact	500
			contact/ coil	500
			contact/ shield	500
			coil/ shield	500
Insulation resistance	min	A	10 ⁹	
Admissible ambient temperature			-25°C ÷ 55°C	

3. LIST OF COILS AND OPERATING VOLTAGE RANGE

Symbol of relay	Contact arrangement _t	Index No	Coil resistance R _N [A] t = 20°C	Supply voltage, t = 20°C		
				U _N [V]	U _{MIN} [V]	U _{MAX} [V]
K-32/1x2 K-32/2x2	1 form B 2 form B	8-4441-675-1 8-4441-676-1	100 ± 10% 100 ± 10%	6	4,2 4,7	8,5 8,6
K-32/1x2 K-32/2x2	1 form B 2 form B	8-4441-675-2 8-4441-676-2	410 ± 10% 410 ± 10%		12	8,5 9,6
K-32/1x2 K-32/2x2	1 form B 2 form B	8-4441-675-3 8-4441-676-3	1640 ± 15% 1640 ± 10%	24		17,8 19,2

4. OPERATING VOLTAGE CONNECTION

Operations	Operating voltage connection	
breaking	+ to terminal 1	- to terminal 10
making	For relays with break contacts, making is achieved by switching off supply voltage	

5. DIMENSIONS AND TERMINAL ARRANGEMENTS

K-32/Nx2

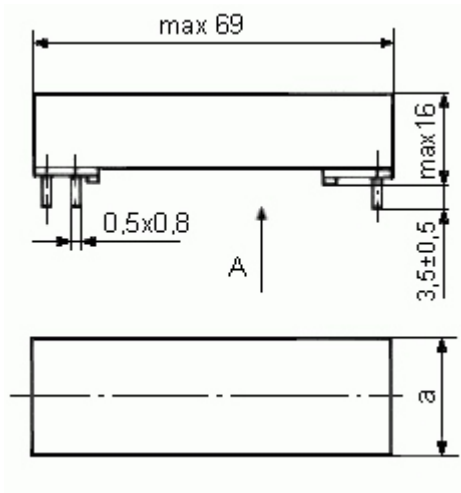

Reed relay	Dimension "a" (max)
K-32/1x2	22,5 mm
K-32/2x2	28,0 mm

View from the bottom side of relay

$m=2,5$

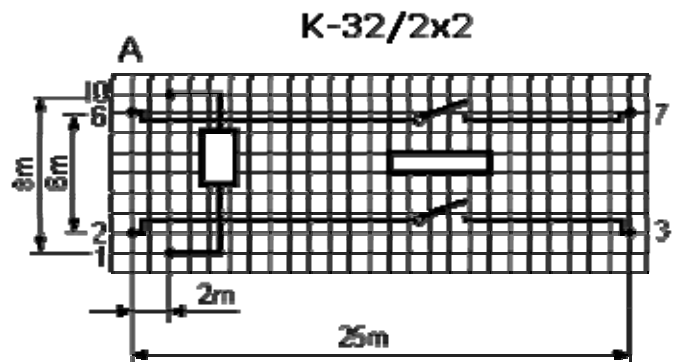
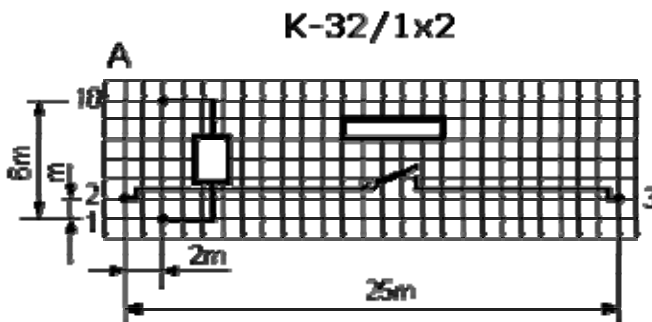

Ordering Information

When ordering relay please specify:

- symbol of relay
- index number

Recommendation for users

When mounting into printed circuit boards, it is advisable to observe the following points to avoid damage to the relays:

- the time of continuous heating of terminals during soldering should not exceed 5 s,
- the soldering iron should not press on terminals during soldering,
- the relays should not be mounted near sources of strong magnetic fields, e.g. transformers, permanent magnets etc.,
- the relays should operate at nominal supply voltages.

JIN ZON ENTERPRISE CO., LTD.

4F-3, No. 171, Sec. 2, Chang An E. Rd.,
Taipei, Taiwan, R. O. C.
TEL: 886-2-27111093~5
FAX: 886-2-27310902
E-mail: jinzon@ms2.hinet.net
Http:// www.jinzon.com.tw/

Reed relays type K-32/1xL

This product is in accordance with RoHS

Reed relay K-32 with 1 bi-stable (with magnetic holding) contact for PCB's.

PARAMETERS	Unit	TYPE
		K-32/1xL

1. CONTACT PARAMETERS

Switching power	max	W, VA	60
Switching voltage	max	V_{DC}	200
		V_{AC}	230
Switching current	max	A	1
Contact resistance	max	mA	150
Life expectancy at 60V, 1A		operations	$7,5 \times 10^6$

2. RELAY PARAMETERS

Operating voltage range		V	Pulse power supply (pulse width not less than 2.5 ms) see p. 3 and 4
Coil resistance		A	see p.
Operate time	max	ms	2,5
Release time	max	ms	2,5
Test voltage:			
contact			400
contact/ contact			500
contact/ coil	min	V_{AC}	500
contact/ shield			500
coil/ shield			500
coil/ coil			100
Insulation resistance	min	A	10^9
Insulation resistance winding - winding	min	A	2×10^8
Admissible ambient temperature			-25°C do 55°C

3. LIST OF COILS AND OPERATING VOLTAGE RANGE

Symbol of relay	Contact arrangement	Index No	Coil resistance R_N [A] $t = 20^\circ C$	Supply voltage, $t = 20^\circ C$		
				U_N [V]	U_{MIN} [V]	U_{MAX} [V]
K-32/1xL	1 bi-stable	8-4441-678-1	300/300 $\pm 10\%$	6	4,9	8,6
K-32/1xL	1 bi-stable	8-4441-678-2	1200/1200 $\pm 15\%$	12	10,1	16,3
K-32/1xL	1 bi-stable	8-4441-678-3	4800/4800 $\pm 15\%$	24	20,2	32,6

4. OPERATING VOLTAGE CONNECTION

Operation	Pulse power supply with pulse width not less than 2,5 ms	
open	+ to terminal 12	- to terminal 11
close	+ to terminal 1	- to terminal 10

5. DIMENSIONS AND TERMINAL ARRANGEMENTS

K-32/1xL

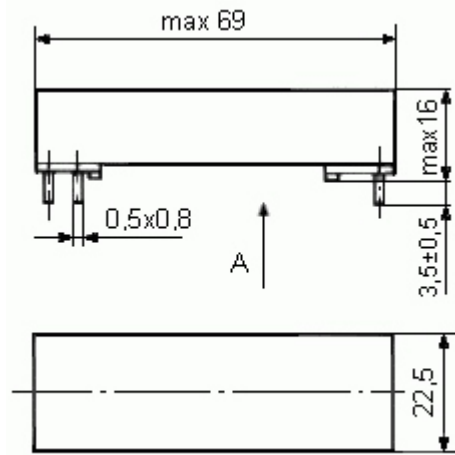

View from the bottom side of relay

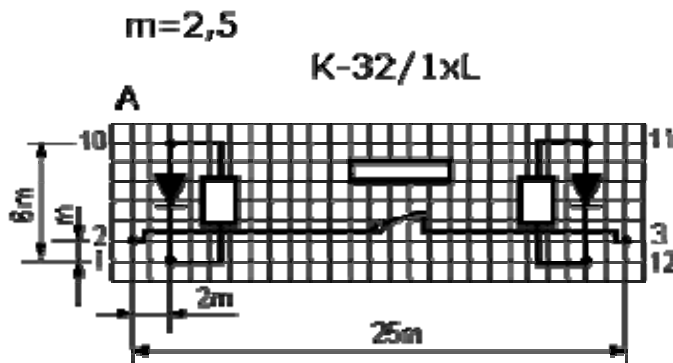

Ordering Information

When ordering relay please specify:

- symbol of relay
- index number

Recommendation for users

When mounting into printed circuit boards, it is advisable to observe the following points to avoid damage to the relays:

- the time of continuous heating of terminals during soldering should not exceed 5 s,
- the soldering iron should not press on terminals during soldering,
- the relays should not be mounted near sources of strong magnetic fields, e.g. transformers, permanent magnets etc.,
- the relays should operate at nominal supply voltages.