

# Application Note

## TADII - Threshold Angle Detector Operation and Calibration Instructions

The SSV0187 is a dual axis threshold angle detector with adjustable hysteresis angles and delay time. There are five open collector outputs (see Figure 2). The two outputs for the Pitch angle (plus & minus) and two outputs for the Roll angle (plus & minus) indicate when the threshold angles have been exceeded (Transistor on). Outputs will automatically reset when the unit is tilted back within the threshold angle minus the hysteresis angle. The other collector is used to indicate two different functions. When the jumper is connected between the common and the mechanical null position (see Figure 3) the output will indicate that the unit is at mechanical null with respect to gravity. When the jumper is connected between the common and the position null, the output will indicate that the unit is within the set threshold limits in both the pitch and roll axes (ref. Figure 1). Four potentiometers are provided to set the pitch and roll thresholds, hysteresis, and delay time (ref. Figure 3). The hysteresis function allows the user to expand the threshold angle as the unit is reset when returned to null. The delay function provides filtering of false signals resulting from shock or vibration. Setting can be either factory adjusted and or set by the user.

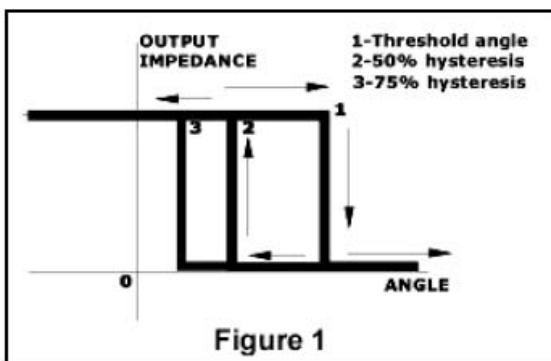

Figure 1

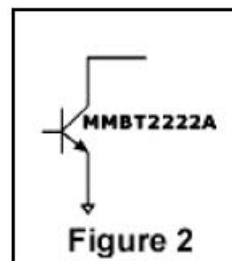

Figure 2

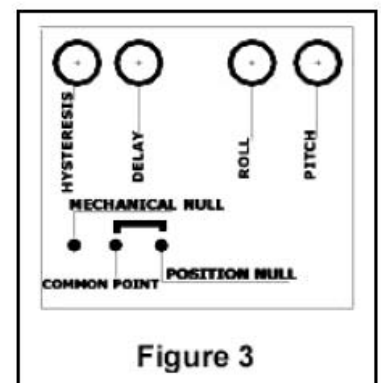

Figure 3

駿融企業有限公司 JIN ZON ENTERPRISE CO., LTD.

104 台北市長安東路二段 171 號 4 樓之 3

4F-3, No. 171, Sec. 2, Chang An E. Rd., Taipei, Taiwan, R. O. C.

TEL: 886-2-27111093~5

FAX: 886-2-27310902

E-mail: [jinzon@ms2.hinet.net](mailto:jinzon@ms2.hinet.net)

Http:// [www.jinzon.com.tw/](http://www.jinzon.com.tw/)

# Application Note

## TADII - Threshold Angle Detector Operation and Calibration Instructions

**Diagram 1 ( 0.3° trip angle, zero hysteresis)**

Output	Roll < -0.3°	-0.3° < Roll < 0.3°	Roll > 0.3°	Pitch < -0.3°	-0.3° < Pitch < 0.3°	Pitch > 0.3°
Pin 2	HIGH	(Note 1)	HIGH	HIGH	(Note 1)	HIGH
Pin 3	-	-	-	HIGH	HIGH	LOW
Pin 4	-	-	-	LOW	HIGH	HIGH
Pin 5	LOW	HIGH	HIGH	-	-	-
Pin 6	HIGH	HIGH	LOW	-	-	-

Note 1: If the roll and pitch are within 0.3 degrees (above example) the output is LOW. If the high Current option is selected the output will be HIGH.

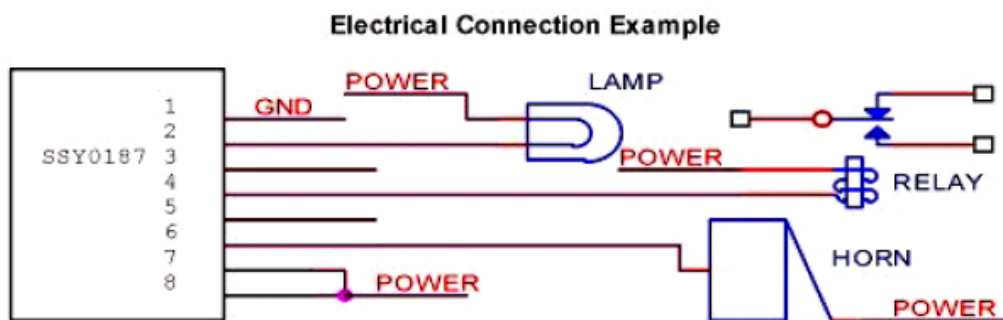

### Part Number Composition

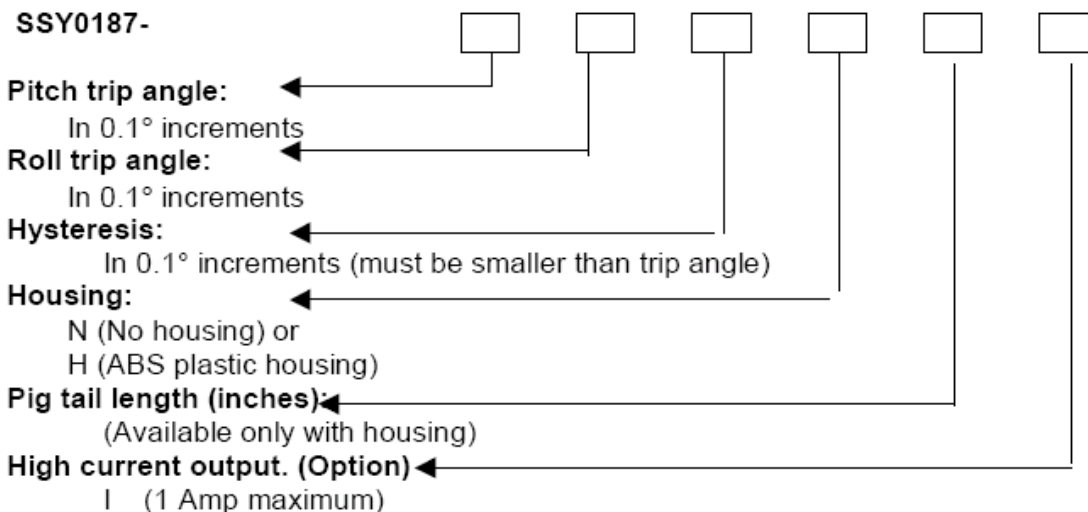

駿融企業有限公司 JIN ZON ENTERPRISE CO., LTD.  
 104 台北市長安東路二段 171 號 4 樓之 3  
 4F-3, No. 171, Sec. 2, Chang An E. Rd., Taipei, Taiwan, R. O. C.  
 TEL: 886-2-27111093~5 FAX: 886-2-27310902  
 E-mail: [jinzon@ms2.hinet.net](mailto:jinzon@ms2.hinet.net) Http:// [www.jinzon.com.tw/](http://www.jinzon.com.tw/)

# Application Note

## TADII - Threshold Angle Detector Operation and Calibration Instructions

### Part Number Composition (contd.)

#### Examples

(1) A unit with a 10 degree trip angle for both pitch and roll, a 1 degree reset angle, and enclosed in an AB plastic housing with five inch pigtail leads would be ordered as part number *SSY0187-100-100-90-H-5*. If these same specifications were ordered with the high current option the designated part number would be *SSY0187-100-100-90-H-5-I*

(2) A unit with a .3 degree trip angle for pitch, a .5 degree trip angle for roll, a 0.1 degree hysteresis angle and no housing the designated part number would be *SSY0187-3-5-1-N*.

**Note:** *trip angle ñ hysteresis = reset angle.*

### Specifications

#### Electrical

Supply voltage.....+7.5VDC to +30VDC  
Supply current..... 10mA  
Output voltage, max.....+40VDC Transistor is off.  
Output voltage, min.. ..... 0.6VDC Transistor is on. Output  
current, max.....100mA (Note)  
Operating temperature.....-30°C to +70°C . . Storage  
temperature..... -55°C to +125°C

*Note. If user selects the high current output option, the maximum current is 1Amp.*

#### General

Threshold angle, adjustable..... from 0.1° to 40° (Sensor dependent.)  
Resolution.....better than 1% of threshold angle.  
Hysteresis, adjustable.....from 1% to 100% of threshold angle.  
Response time ..... Sensor dependent.  
Delay time, adjustable.....from 0 to 2 sec. Mechanical  
Null .....10% of threshold angle.  
Accuracy (setting) ..... 0.1° or trip angle ~ 25, whichever is greater

駿融企業有限公司 JIN ZON ENTERPRISE CO., LTD.  
104 台北市長安東路二段 171 號 4 樓之 3  
4F-3, No. 171, Sec. 2, Chang An E. Rd., Taipei, Taiwan, R. O. C.  
TEL: 886-2-27111093~5 FAX: 886-2-27310902  
E-mail: [jinzon@ms2.hinet.net](mailto:jinzon@ms2.hinet.net) Http:// [www.jinzon.com.tw/](http://www.jinzon.com.tw/)

# Application Note

## TADII - Threshold Angle Detector Operation and Calibration Instructions

### Connector Wiring

Pin/Color

1 / BLACK	GROUND
2 / ORANGE	PITCH AND ROLL ZERO
3 / BROWN	PITCH POSITIVE
4 / BLUE	PITCH NEGATIVE
5 / YELLOW	ROLL POSITIVE
6 / WHITE	ROLL NEGATIVE
7 / GREEN	POWER (SUPPLY VOLTAGE)
8 / RED	POWER (SUPPLY VOLTAGE)

### Adjustments

Recommended electrical arrangement is shown below. This circuit helps to indicate the activated outputs during threshold and mechanical null adjustments.

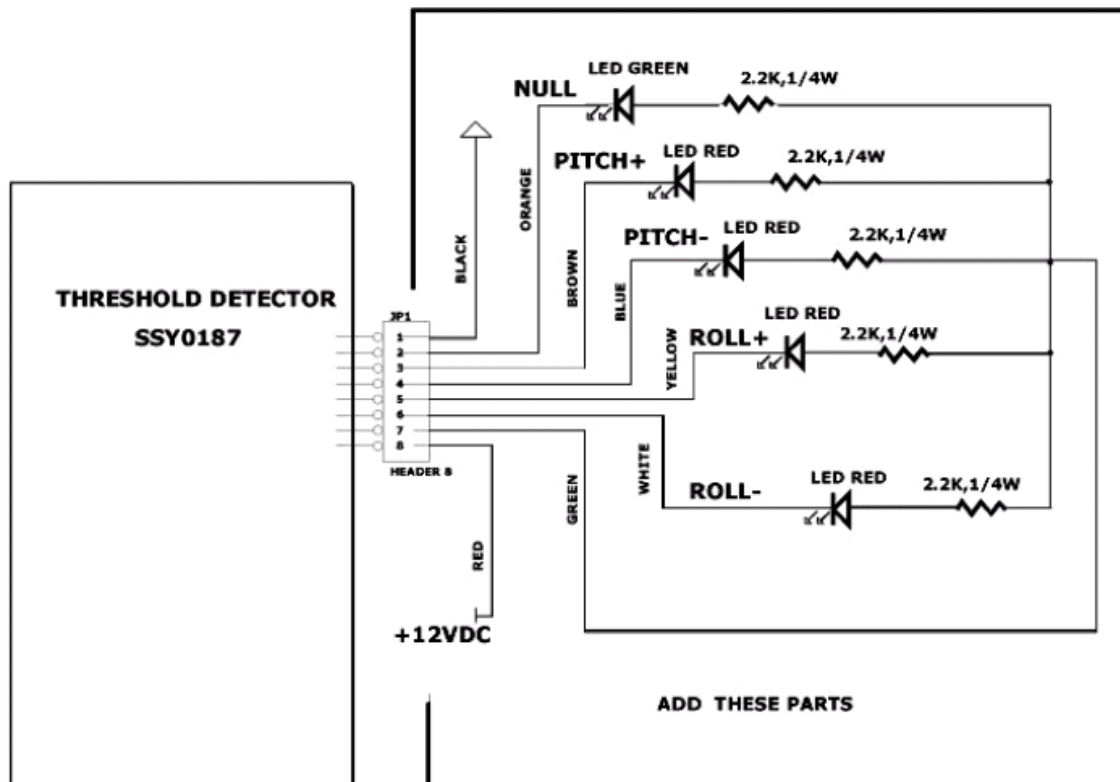

駿融企業有限公司 JIN ZON ENTERPRISE CO., LTD.

104 台北市長安東路二段 171 號 4 樓之 3

4F-3, No. 171, Sec. 2, Chang An E. Rd., Taipei, Taiwan, R. O. C.

TEL: 886-2-27111093~5

FAX: 886-2-27310902

E-mail: [jinzon@ms2.hinet.net](mailto:jinzon@ms2.hinet.net)

Http:// [www.jinzon.com.tw/](http://www.jinzon.com.tw/)

# Application Note

## TADII - Threshold Angle Detector Operation and Calibration Instructions

### Calibration Instructions

1. Set the Detector board in the fixture (enclosure). Three mounting screws should be used.
2. Set the fixture on a rotating platform in the Pitch direction. Set platform horizontally.
3. Set the jumper in the Mechanical Null position.
4. Connect board to 12VDC power supply: RED wire to PLUS, BLACK wire to COMMON (return).
5. **Initial adjustment of Delay and Hysteresis.** Turn on power supply. Adjust DELAY trimpot to get 0.01-0.05 VDC on the center tap. The delay is now set to zero. Adjust HYSTERESIS trimpot to 4.8-4.9 VDC on the center tap. T hysteresis is now set to zero.
6. **Null adjustment preset.** Tilt platform 1 degree in Pitch direction. Adjust Pitch trimpot to trigger the Pitch LED. Rotate board fixture 90 degrees. Adjust Roll trimpot until Roll LED is illuminated. Return platform to horizontal position.
7. **Mechanical Null adjustment.** Adjust board screws so the GREEN LED starts to light up. When the LED is in this stage it indicates that null is found across only one axis. The LED is being triggered by 1ms pulses with a frequency of 40Hz. When null is found across both axes, the LED is brightly illuminated. The LED is now being triggered by 12ms pulses with a frequency of 40Hz.
8. **Roll setting.** Tilt board in a roll direction to the requested threshold angle. Adjust the ROLL trimpot so that one of the RED ROLL LED's is illuminated. This indicates that the board will detect both plus and minus ROLL thresholds. Return platform to horizontal position. If the angle is less than 1 degree repeat step7.
9. **Pitch setting.** Rotate board fixture 90 degrees relative to the initial position. Tilt board in a pitch direction to the requested threshold angle. Adjust the PITCH trimpot so that one of the RED PITCH LED's is illuminated. This means that the board will detect both plus and minus PITCH thresholds. Return platform to horizontal position. If threshold angle is less than 1 degree repeat step7.
10. **Hysteresis setting.** When setting the hysteresis, the voltage (Vh) on the center tap of the HYSTERESIS trimpot is set as follows:  **$V_h = 4.9 - 2.35(H\%/100)$** . (H% is the requested width of hysteresis relative to the pitch and roll angles.)  
*Note.* Hysteresis of both axes are equal in terms of percentage, i.e. if ROLL hysteresis is 20% of the ROLL threshold, the PITCH hysteresis is 20% of the PITCH threshold.
11. **Delay set.** Calculate voltage corresponding to the required Delay in seconds. Center tap voltage on the DELAY trimpot =  **$0.75 \times \text{delay}$**  [sec]. For example, if delay time is to be set 1sec DELAY the trimpot should be adjusted to 0.75V on the center tap.
12. **Set and check NULL POSITION.** Turn off power supply. Set jumper in NULL POSITION. Turn on power supply. Tilt platform to horizontal position. When the GREEN NULL LED is illuminated and the RED LEDS are not, you have reached the NULL POSITION.
13. **Calibration is completed.** Turn off power supply. Release board

駿融企業有限公司 JIN ZON ENTERPRISE CO., LTD.

104 台北市長安東路二段 171 號 4 樓之 3

4F-3, No. 171, Sec. 2, Chang An E. Rd., Taipei, Taiwan, R. O. C.

TEL: 886-2-27111093~5

FAX: 886-2-27310902

E-mail: [jinzon@ms2.hinet.net](mailto:jinzon@ms2.hinet.net)

Http:// [www.jinzon.com.tw/](http://www.jinzon.com.tw/)