

General Description

The KMR 360 is a new patented development by HL Planartechnik GmbH. This magnetic field sensor utilizing the anisotropic magnetoresistance effect. The sensor contains three Wheatstone bridges rotated by 120°. A rotating magnetic field (strength > 25 kA/m in the sensor plane) will result in three sinusoidal output signals phase shifted by 60°, allowing simple angular evaluation by linear interpolation. Alternatively, the CORDIC algorithm may be used to calculate the rotation angle more exactly.

As an additional feature, the KMR360 is able to measure full 360° by using an additional magnetic field, which is generated by a planar coil located on the chip.

Function principle:

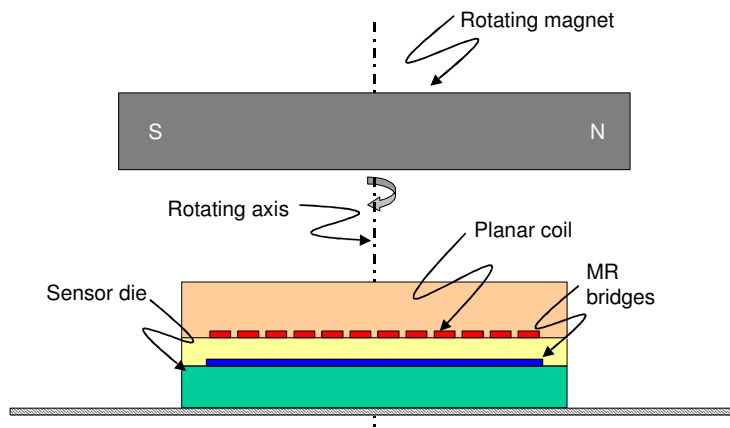

Fig: 1 Sensor element and magnet set up for rotational measurement

Circuit model

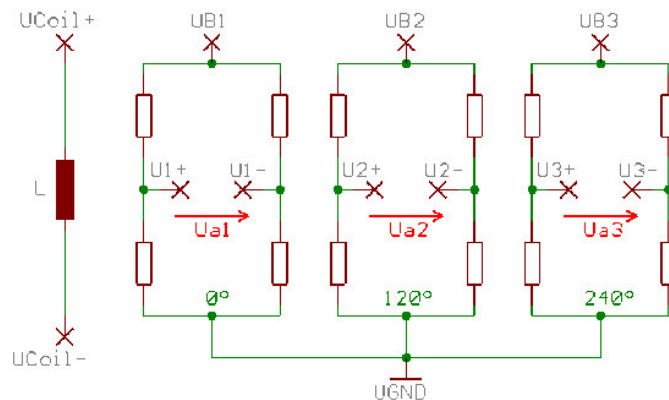

Fig. 2: The schematic circuit of KMR360.

Function description:

U_{GND} , U_{Bn} , U_{n+} , U_{n-} , U_{coil+} and U_{coil-} refer to the pin name ($n=1,2,3$) resp..

U_{an} are the bridge output voltages, i.e. the voltage difference between pin U_{n+} and pin U_{n-} .

In order to power the coil with a positive coil current I_{coil+} , the voltage applied to pin U_{coil+} must be greater than the voltage applied to pin U_{coil-} . In order to power the coil with a negative coil current I_{coil-} , the voltage applied to pin U_{coil+} must be smaller than the voltage applied to pin U_{coil-} .

Characteristic Curves

The working principle of the KMR360 is shown in figures 3 and 4: Figure 3 depicts the output signals U_{an+} respective U_{an-} of the $n=1,2,3$ Wheastone bridges with an additional coil field created by alternate coil current I_{coil+} respective I_{coil-} .

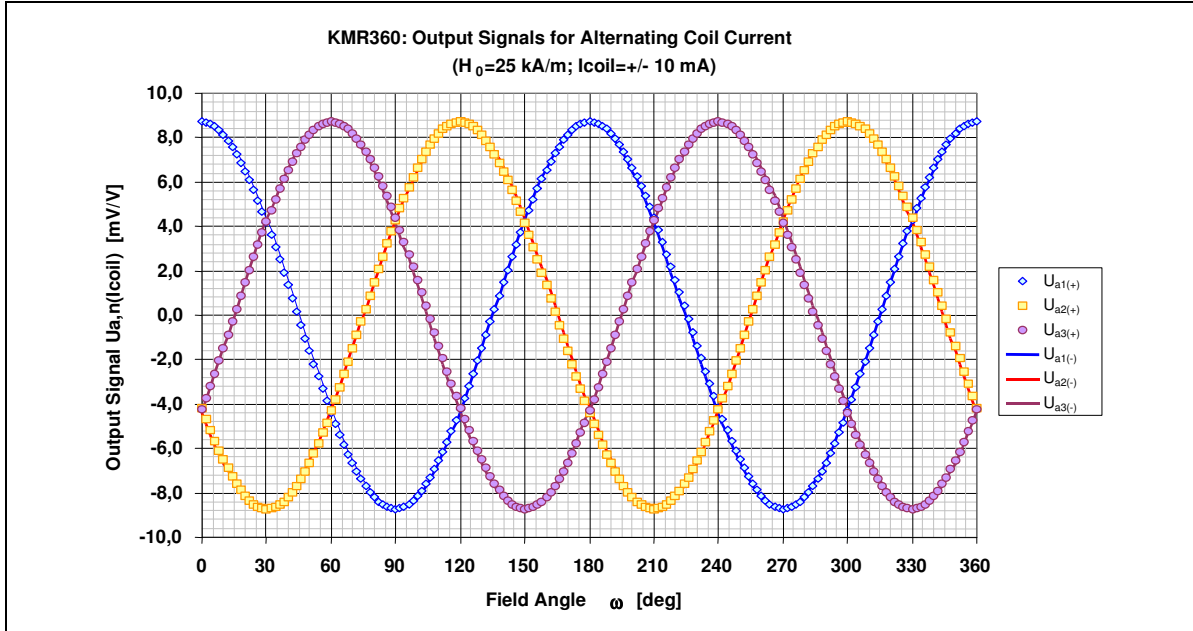

Fig. 3: Typical output signal curves without (solid) and with (dashed) coil field for KMR360

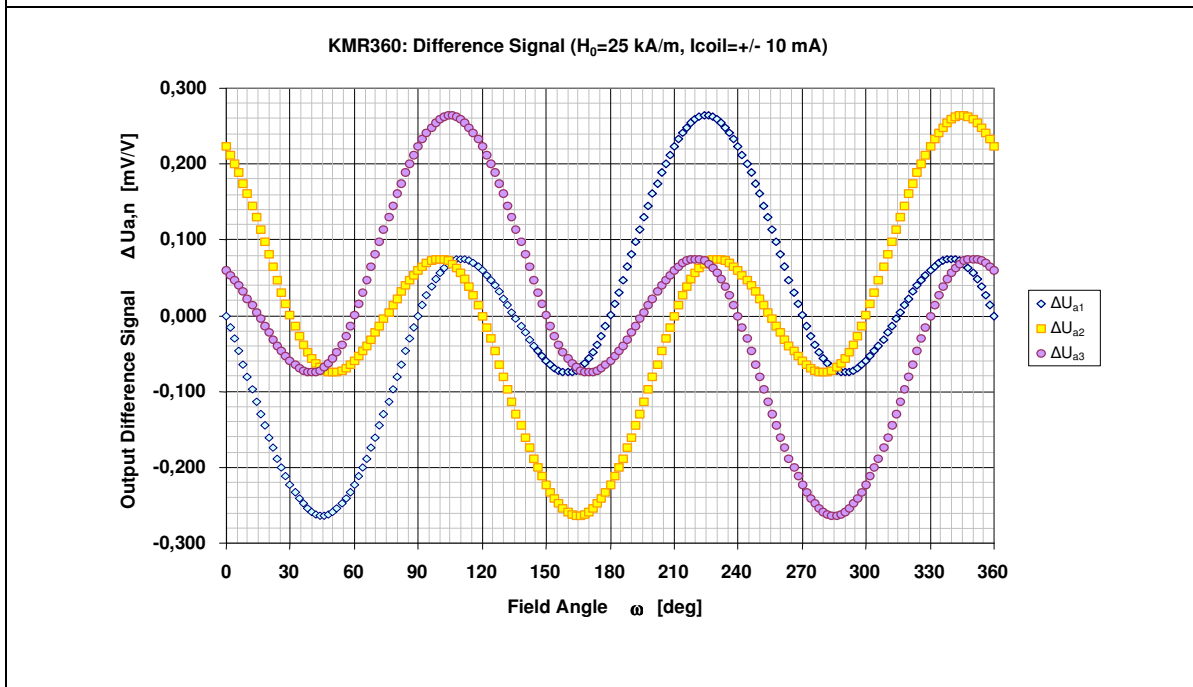

Fig. 4: Signal change due to additional coil field

Fig. 4 shows their difference signals $\Delta U_{an} = U_{an+} - U_{an-}$.
By analysing the signs the calculated angle can clearly be assigned within a range of $0^\circ \dots 360^\circ$.

Specification:

Parameter	Condition	Symbol	Min	Typ	Max	Unit
Mechanical Dimensions						
Chipsize				1.8x1.8		mm*mm
Chip thickness				400		µm
Padsizes				120*120		µm*µm
Padmaterial	Aluminium	d_{Al}		1		µm
Operation Limits						
Max. voltage	depends on package	$U_{cc,max}$		10		V
Max. current	sense current	$I_{cc,max}$		10		mA
Operating temperature		T	-40		+125	°C
Storage temperature		T_{st}	-40		+125	°C
Temperature range for TC measurements		T_m	-25		+125	°C
Sensor Specification						
Applied magnetic field		H_{appl}	TBD	35	TBD	kA/m
Bridge resistance		R_b	0.8	1	1.2	kΩ
Signal amplitude	$H_{appl} = 50 \text{ kA/m}, T=RT$	$\Delta U/U$	15	TBD	TBD	mV/V
Angular accuracy	$H_{appl} = 25 \text{ kA/m}, T=RT; U_{off} < 0.5 \text{ mV/V}$	$\Delta \alpha$			2	°
Offset voltage		U_{off}	-5		+5	mV/V
TC of amplitude	$-25^\circ\text{C} < T_m < +125^\circ\text{C}$	TCU	-0.35	-0.32	-0.29	%/K
TC of resistance	$-25^\circ\text{C} < T_m < +125^\circ\text{C}$	TCR	0.28	+0.32	+0.36	%/K
Coil Specification						
Coil resistance		R_{coil}	TBD	200	TBD	Ω
Coil current	AC	I_{coil}	-	10	TBD	mA
	DC continous				8	
	DC pulsed				50	
Coil induced angular change	@ $H_{appl} = 25 \text{ kA/m}; I_{coil} = 25 \text{ mA}; T=RT$	$\Delta \theta$	0.5			°

Patent protected.
Preliminary technical Information.

This product is not designed for use in life support appliances, devices or systems where malfunction of this product can reasonably be expected to result in personal injury. HL Planartechnik GmbH customers using or selling this product for use in such applications do so at their own risk and agree to fully indemnify HL Planartechnik GmbH for any damages resulting from such improper use or sale.

This data sheet contains target specifications for product development which can be subject to change without notice.

